

# 3M™ Textool™ Open-Top Test and Burn-In Sockets for Ball Grid Array Packages



**3M** *Innovation*

# 3M™ Textool™ Open-Top Sockets for BGA Packages

## Table of Contents

- Product Advantages ..... 1
- Contact Durability..... 1
- Contact Reliability ..... 2
- Micro-Wiping and Solder Ball Deformation..... 3
- Package Alignment ..... 4
- Package Dimension Requirements ..... 5
- Socket Mechanism and Operating Instructions ..... 6
- Ordering Information..... 8
- 3M Textool Open-Top BGA Sockets 0.65 mm ..... 9
- 3M Textool Open-Top BGA Sockets 0.80 mm ..... 10
- 3M Textool Open-Top BGA Sockets 1.0 mm ..... 11
- 3M Textool Open-Top BGA Sockets 1.27 mm ..... 12

For the most current product and technical information, click on the product names within this PDF, which will take you to the specific 3M Textool Test and Burn-In Sockets product page on the website.

# 3M™ Textool™ Open-Top Sockets for BGA Packages

First to market in 1992 with BGA sockets, 3M continues to expand our product range and available options. The versatile product design and four product platforms enable quick-turn and low cost proliferation of new sizes. 3M provides reliable performance for test and burn-in applications, with a proven design perfected with years of customer experience. 3M provides sockets for most types of BGA packages, standard or custom, in a variety of pitches, including 0.65 mm, 0.80 mm, 1.00 mm and 1.27 mm.

## 3M Textool Open-Top Test and Burn-in Sockets provide the following benefits:

### Dual-Beam Contact Design

- Minimizes ball deformation with low actuation force, minimal shear stress and contact points above center plane
- Maximizes contact durability due to lower stress per contact beam
- Enhances electrical reliability by expanding contact interface zone

### Micro-Wiping Effect

- Optimizes contact interface by removing oxide build-up
- Minimizes solder transfer to contact tips

### Open-Top Socket Design

- Accommodates a wide range of package dimensions
- Compatible with most automated device loaders
- Enables easy manual operation with low actuation force
- Can reduce lead time and cost with modular tooling and optimal footprint density

### Global Support

- Local sales and technical service personnel in all major markets worldwide
- Design resources and materials expertise in both the United States and Japan
- Quick-turn product samples shipped anywhere in the world
- Website provides easy access to technical information worldwide

## 3M Contact Durability

3M's dual-beam contact increases socket durability with its patented dual-beam motion.

### 3M's Dual-Beam Contact Motion

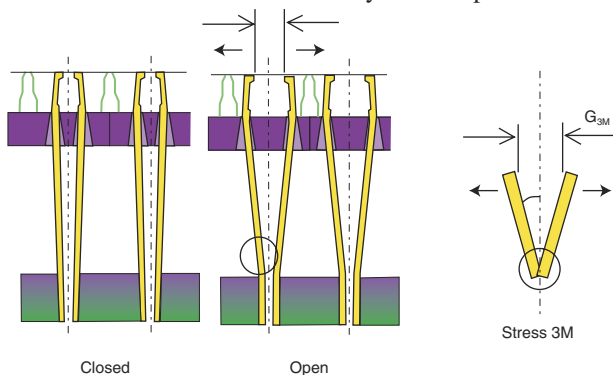

### Single-Beam Contact Motion

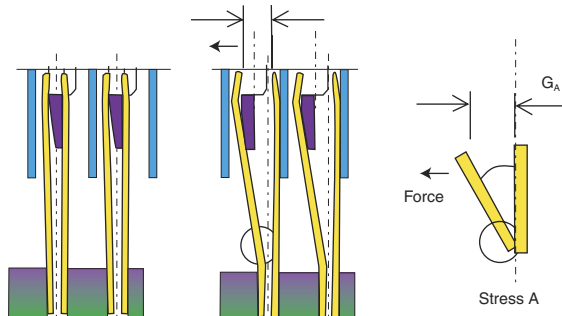

- Since both beams of the 3M contact are moving, each one only has to move  $G_{3M}/2$ .
- For a single beam contact to accommodate the same ball ( $G_{3M} = G_A$ ), one beam must cover the entire gap, thus accelerating the force applied to the beam in motion as the contact travels.
- The added stress of additional travel in the single beam contact increases the likelihood of fatigue-related failures.
- The dual-beam motion of the 3M Textool socket contact prolongs socket mechanical life cycle, which may decrease total cost of ownership.

# 3M™ Textool™ Open-Top Sockets for BGA Packages

## 3M Contact Reliability

3M's micro-wiping contact increases electrical reliability and is intended to decrease total cost of ownership.

### Competition's Edge-Point Contact

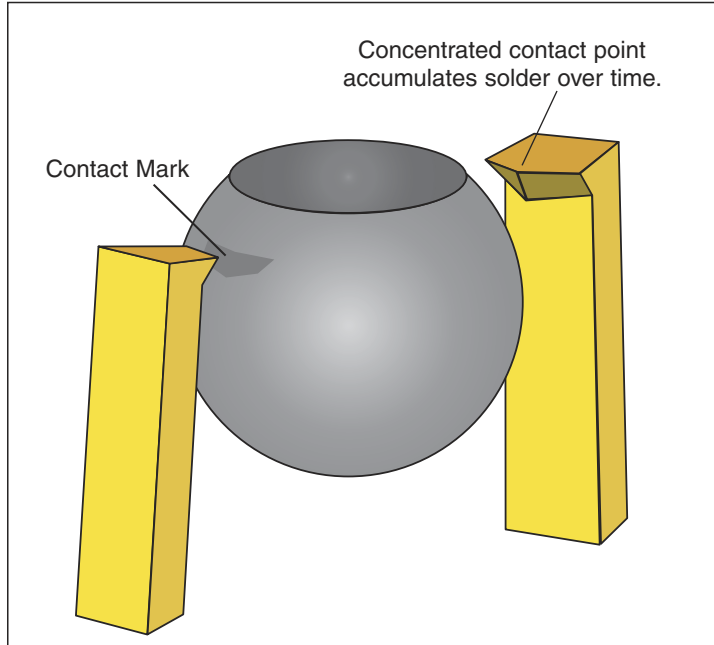

### Piercing Contact

- Encourages solder build-up over time, which in turn increases long-term electrical resistance and decreases reliability.
- Can reduce socket total life cycle and may increase total cost of ownership.
- Expensive cleaning and restoration procedures are sometimes necessary, requiring added cost and board downtime.

### 3M's Micro-Wiping Contact

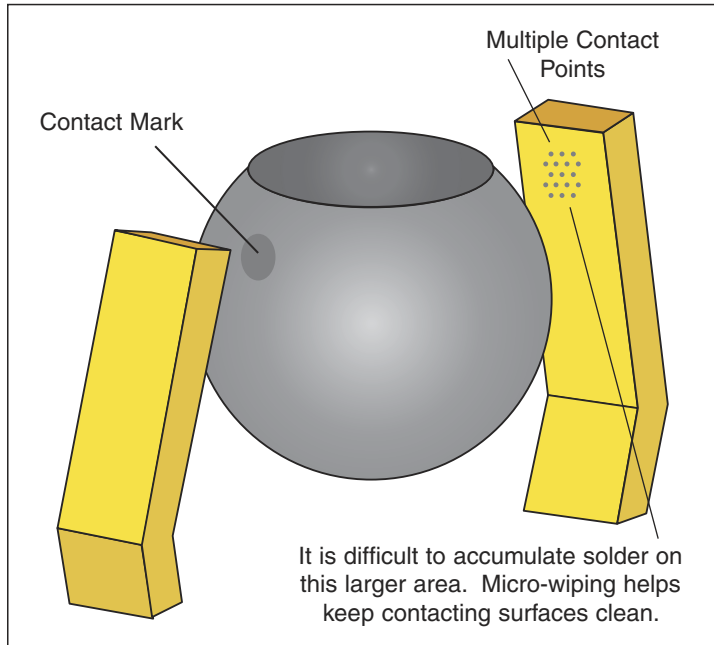

### 3M's Dual-Beam Micro-Wiping Contact

- Provides larger contact area and micro-wiping motion to reduce solder build-up over time, thus maintaining long-term electrical resistance, increasing reliability and prolonging the life cycle of the socket.
- Can decrease total cost of ownership.

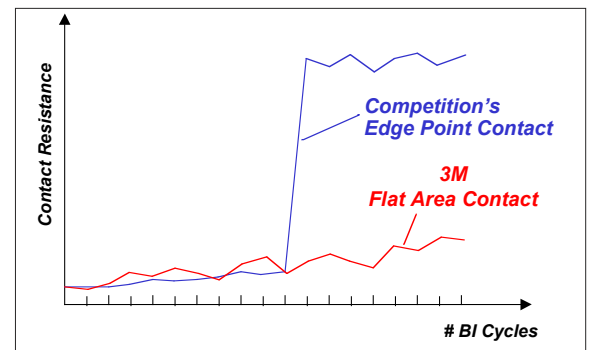

# 3M™ Textool™ Open-Top Sockets for BGA Packages

## Micro-Wiping and Solder Ball Deformation

- The contact arms grasp the solder ball above its center. The shape of the contact arm exerts a component of the applied force in a downward direction, enhancing package retention.
- The dual-beam contact provides balanced forces, reducing the shear stress on the solder ball.

$$F_R = F_L$$

Note:  $F_L$  = Force Left,  $F_R$  = Force Right

**1.27 mm**

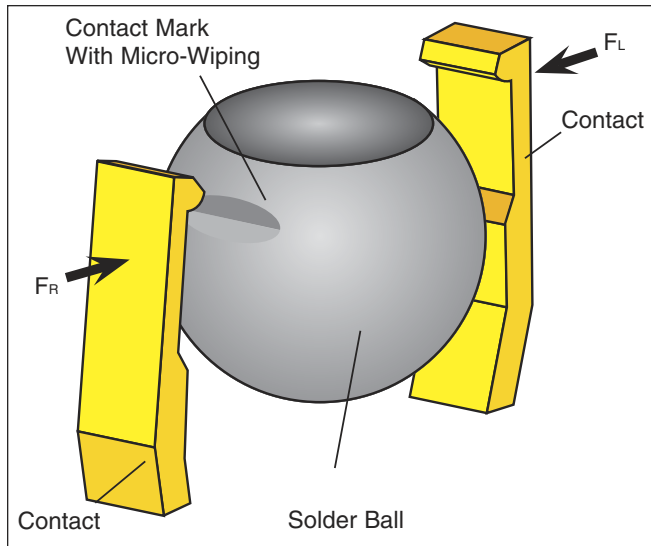

**1.00 mm, 0.80 mm, 0.65 mm**

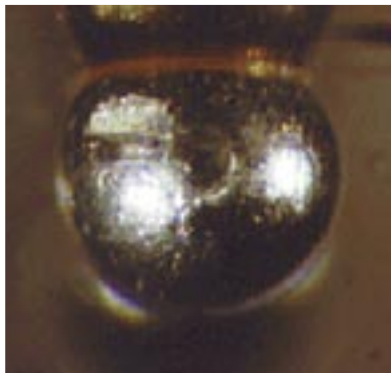
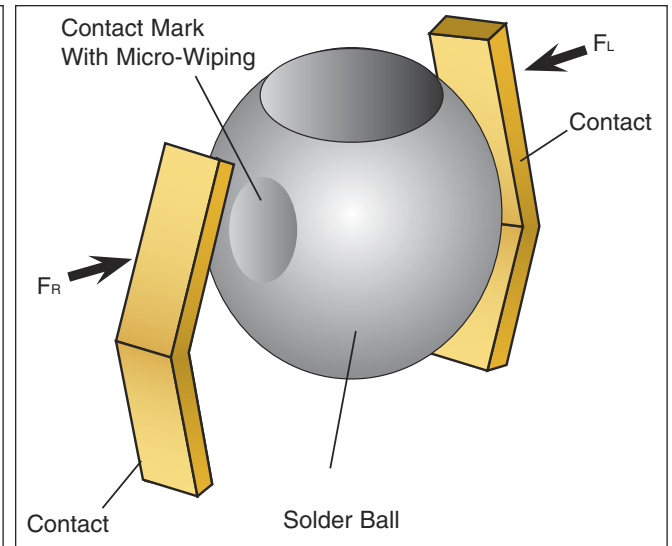

**1.27 mm Solder Ball Deformation  
After 48 Hours at 125°C**

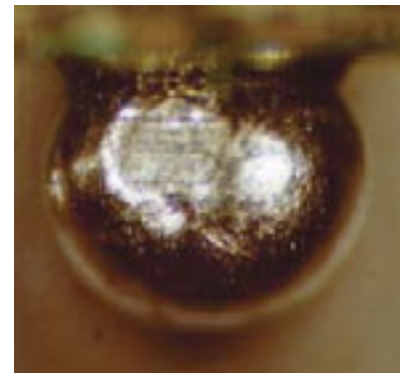

**1.0 mm Solder Ball Deformation  
After 24 Hours at 125°C**

The 3M Textool Open-Top BGA Socket contact is designed to minimize deformation of the solder ball. This is achieved by means of a low-force, dual-beam design that touches the ball at two opposing points away from the BGA seating plane. The result is a system producing only minor indentations which have no effect on solder ball coplanarity.

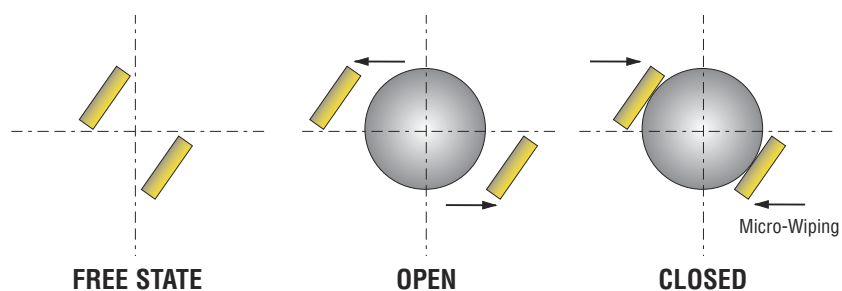

# 3M™ Textool™ Open-Top Sockets for BGA Packages

## Package Alignment

### Loading Sequence

See Illustration Below

1. The top cover is pushed down until fully depressed.
2. The downward motion of the top cover is translated to lateral motion bringing the package guides to the loading position. Concurrently, the nest combs move to open the contact arms to the open position.
3. A BGA package is loaded between the guides to achieve proper alignment of solder balls with socket contacts.
4. Raised features on the nest serve as physical stops that control package entry to the correct depth for proper socket operation.

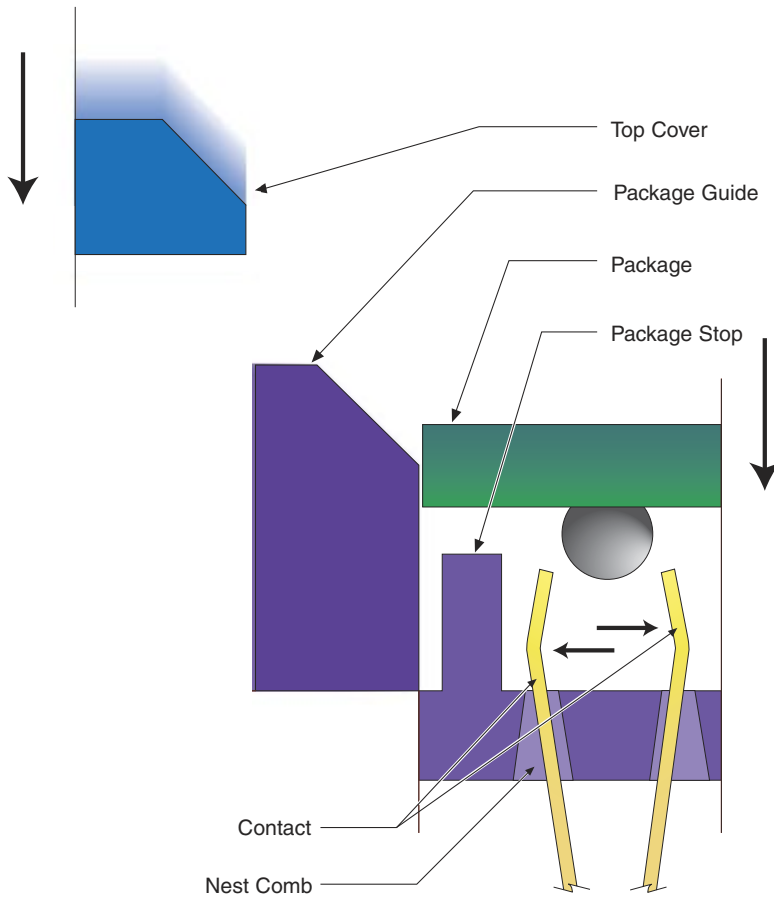

## Socket Construction

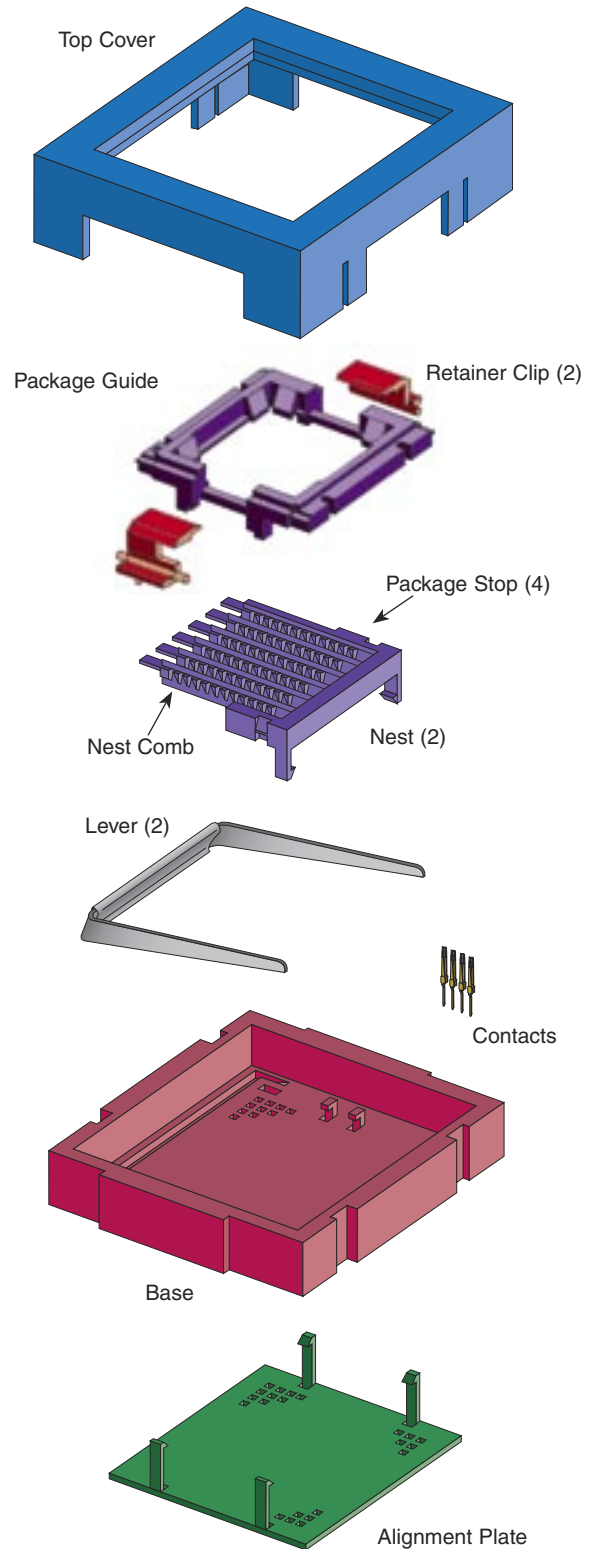

# 3M™ Textool™ Open-Top Sockets for BGA Packages

## BGA Packages and Relation to Socket

BGA packages are available from multiple sources in a wide variety of designs, materials, body sizes, matrices, pin pattern configurations, pitches and thicknesses. To assure proper mating of package to socket and reliable socket performance, all package parameters must be precisely specified and the corresponding socket feature designed to match the package specification. **To properly select or design a socket, the following package dimensions must be specified accurately.**

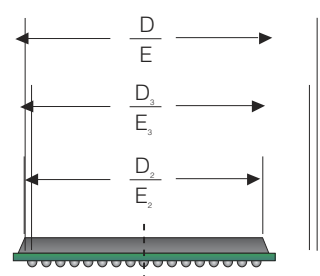
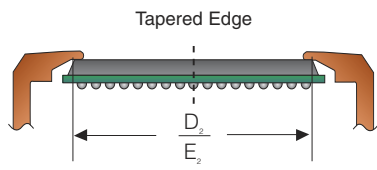
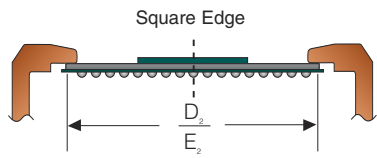
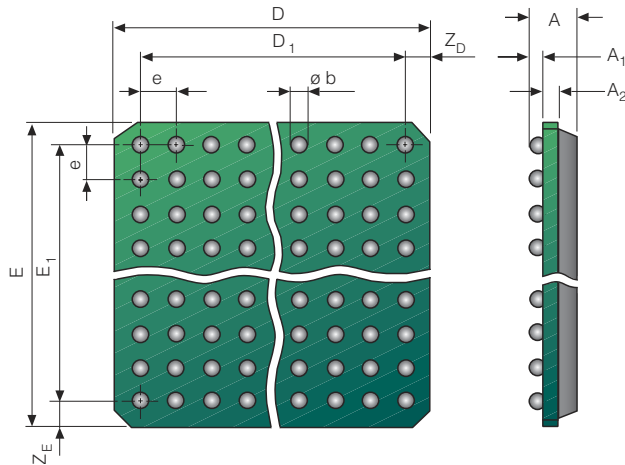

## Essential BGA Package Dimensions

		Dimensions	
Overall Height	A		
Ball Height	$A_1$		$\pm$
Substrate Thickness	$A_2$		$\pm$
Ball Diameter	$\phi b$		$\pm$
Body Size	D		$\pm$
	E		$\pm$
Total Pitch	$D_1$		$\pm$
	$E_1$		$\pm$
† Minimum Mold Cap (If Retainer Clip is Used)	$D_2$		$\pm$
	$E_2$		$\pm$
† Maximum Mold Cap (If Retainer Clip is Used)	$D_3$		$\pm$
	$E_3$		$\pm$
Ball Pitch	e		
Number of Rows	$M_D$		
	$M_E$		
Number of Balls	n		
Package Overhang	$Z_D$		$\pm$
	$Z_E$		$\pm$
Pattern	—		Need Pattern Drawing

† If retainer clip is specified, style of clip depends on package profile. The dimensions  $D_2$  &  $E_2$  and  $D_3$  &  $E_3$  noted at right are required to select the proper clip design.

**Note:** To assure proper match of socket to package, the preferred information is the latest revision of the customer package drawing. The package drawing should contain all of the information in the above table. Send the current package drawing to 3M Customer Service.

## Contact Gap Adjustment

3M Textool Open-Top BGA Sockets are designed to function with common solders under normal production burn-in conditions. In addition, for customers using eutectic solder-balls in long-term testing and/or high-stress environments such as “life testing” and “HAST,” 3M can customize sockets to control solder ball deformation by making an adjustment of the socket contact gap. This adjustment is called “custom gapping” and is based on actual measurement of BGA samples that are provided by the customer. This disclaimer is intended to cover eutectic and other low melt-point solder applications only. Higher melt-point solders, such as 90/10 and lead-free, do not require custom gapping. Please contact 3M Customer Service with your specific needs and conditions. Custom gapping tailors the socket for an exact solder ball diameter and should only be considered for stable production applications where solder ball dimensions are not expected to vary.

# 3M™ Textool™ Open-Top Sockets for BGA Packages

## Socket Mechanism and Operating Instructions

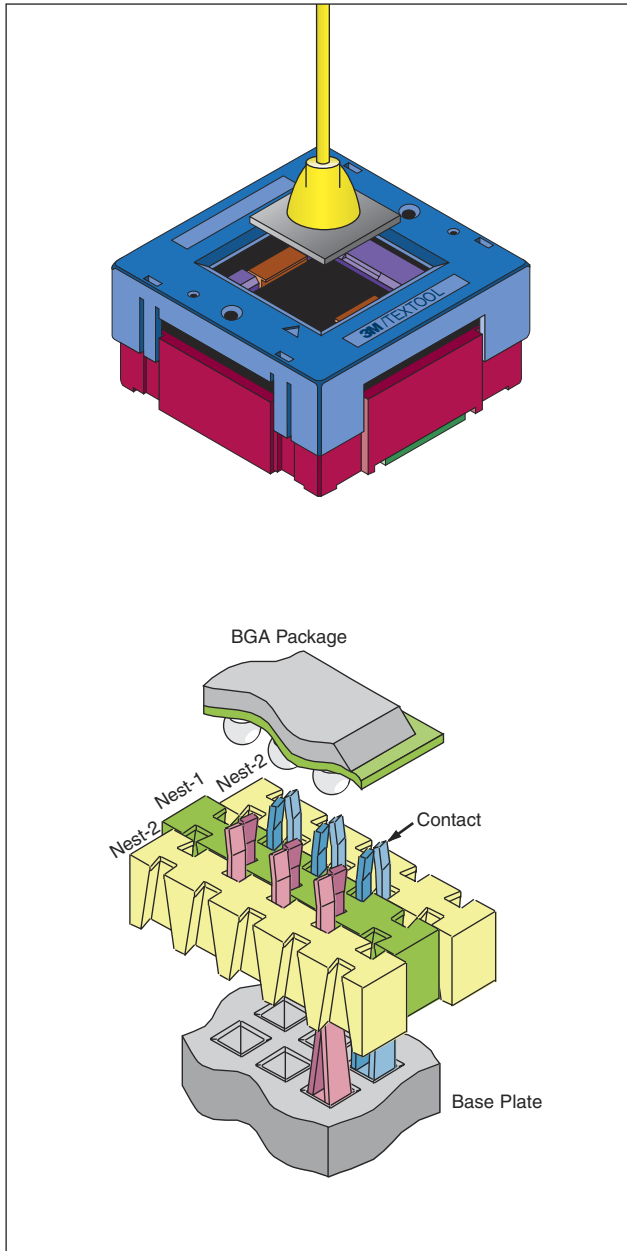

### Stage 1

**Free State.** Socket, with normally closed contacts, in free state, ready for actuation.

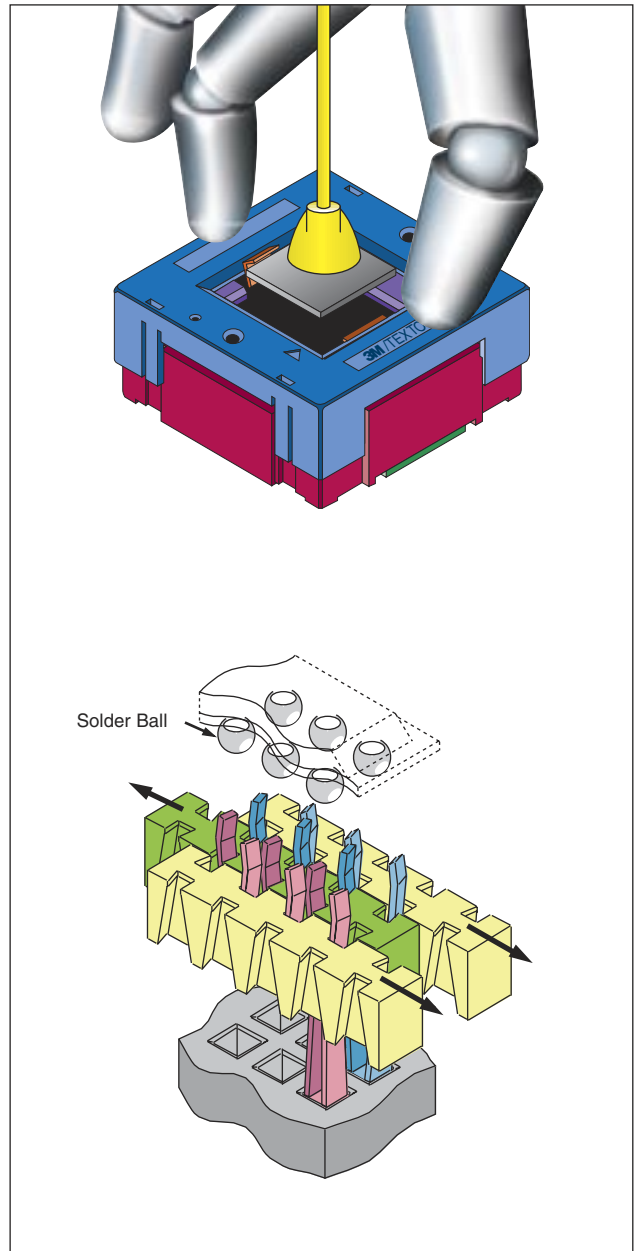

### Stage 2

**Contacts Open.** A downward force is applied to the top plate, which translates to a lateral motion of the nest combs, and opens the contacts to receive the solder ball.

**Note:**

Depress top cover before inserting package.

# 3M™ Textool™ Open-Top Sockets for BGA Packages

## Socket Mechanism and Operating Instructions

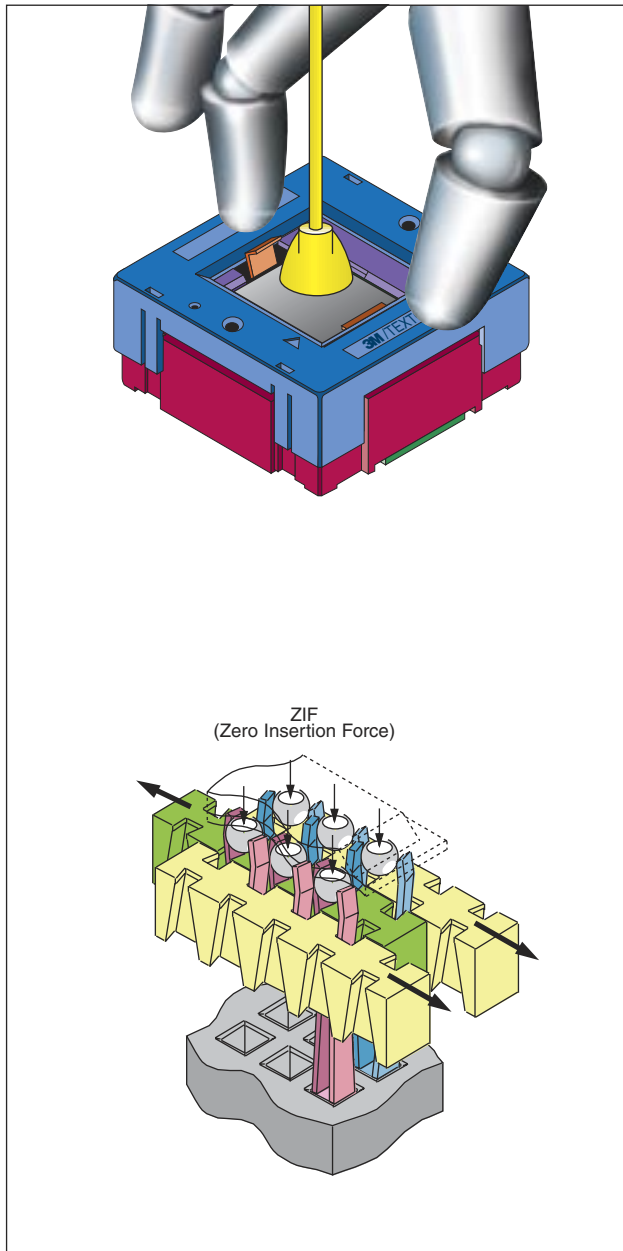

### Stage 3

A BGA device is placed into the top opening. Alignment features guide the package into proper position so each ball rests between the open contact arms.

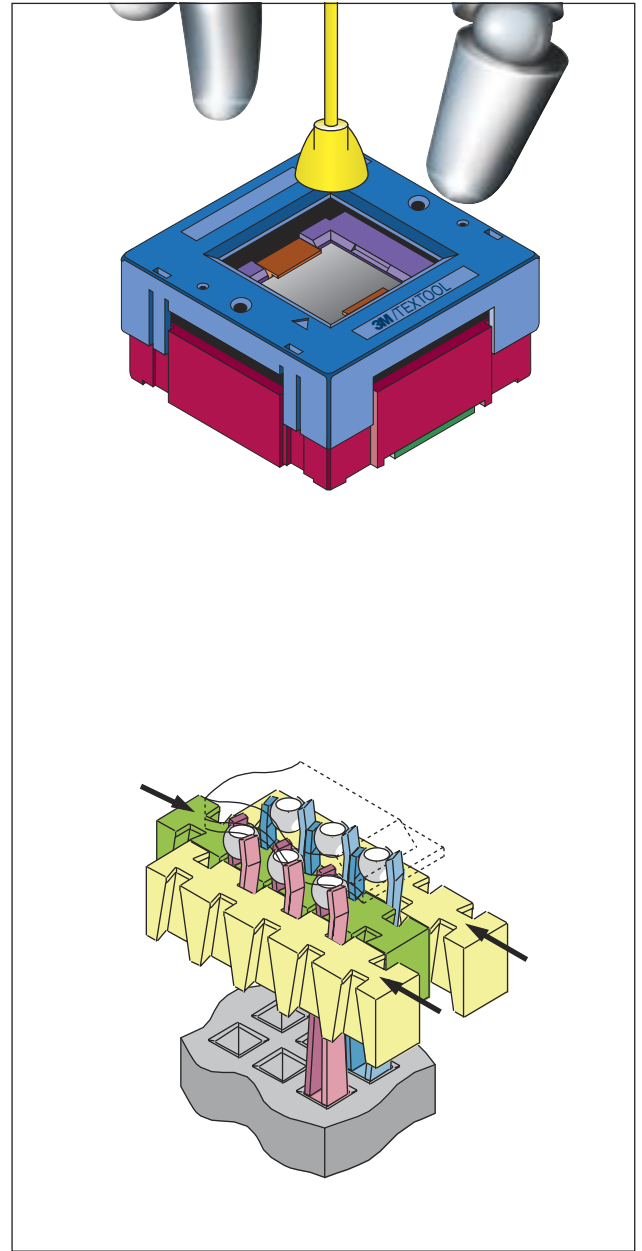

### Stage 4

The vertical actuation force is removed, the contacts close and each ball is gripped above its horizontal center.

# 3M™ Textool™ Open-Top Sockets for BGA Packages

## Ordering Information

1. Submit your detailed package drawing to 3M Customer Service.
2. Specify optional features desired:
  - With or without board locating posts
  - With or without retainer
3. 3M Customer Service will assign complete part number.

## Retainer Clip Feature

3M Textool sockets are designed to function properly without the use of retainer clips. The retainer clip feature is desirable for high vibration/shock applications and with small or non-spherical solder balls or to serve as a visual aid during package loading. The purpose of the retainer clip feature is to retain the DUT in the socket should there be an event or conditions leading to dislodgement of the solder balls from the socket contacts. Retainer clips are custom-designed based on specific package dimensions and should only be considered for stable production applications where package dimensions are not expected to vary. In cases of non-spherical and small solder balls, 3M Technical Service may request package samples for fit analysis.

## Socket Options

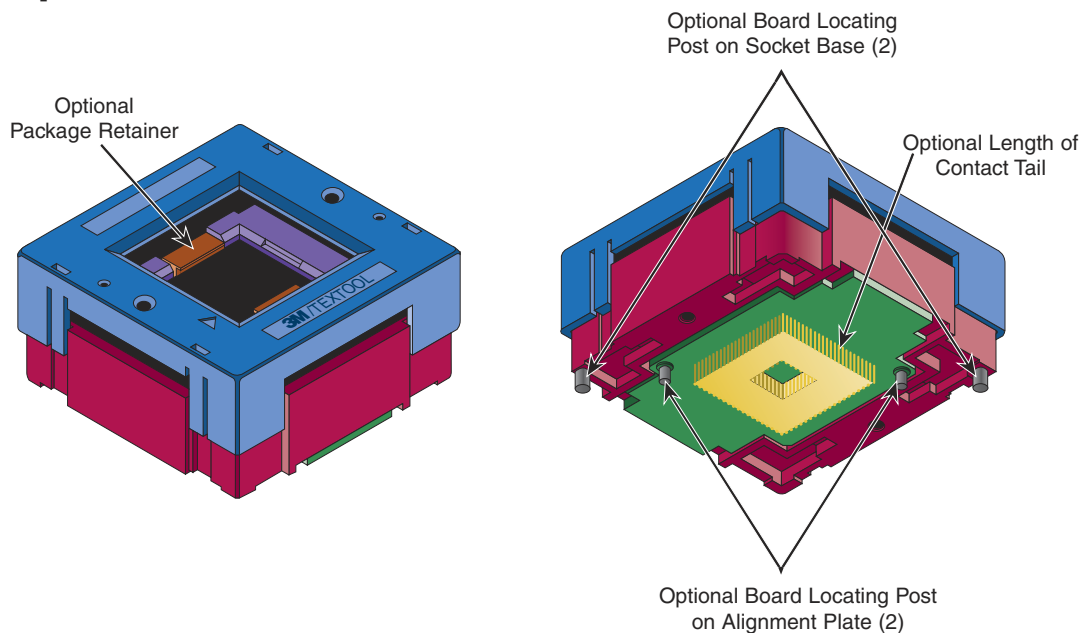

## Socket Part Numbering System

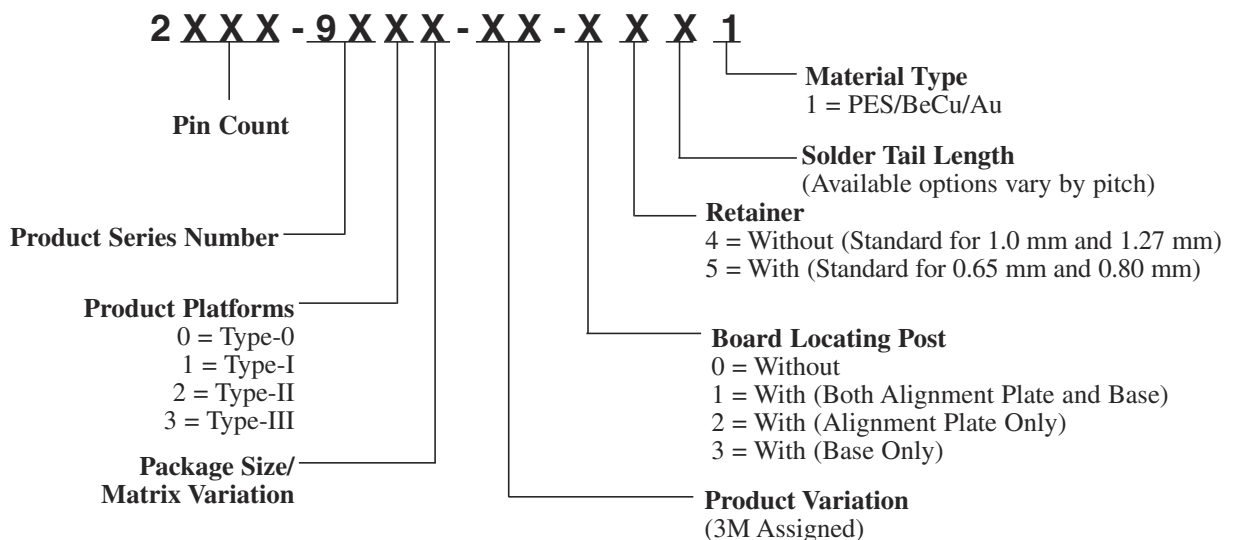

# 3M™ Textool™ Open-Top BGA Sockets 0.65 mm

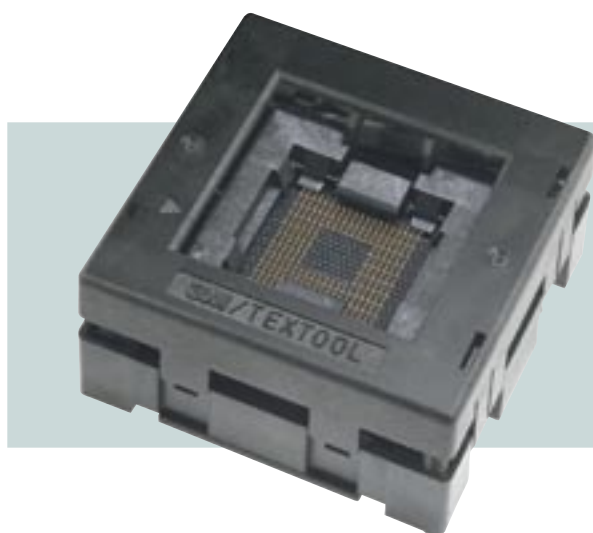

In an effort to better serve our customers, 3M continually updates our technical documents. Please visit our website for the most up-to-date technical information.

[www.3M.com/electronics](http://www.3M.com/electronics)

## BGA 0.65 mm Pitch Socket Platforms

Type	Maximum Body Size (mm)	Maximum Matrix	Maximum Ball Count	Status
I	12x12	17x17	289	Available
II	17x17	25x25	625	Available
III	21x21	31x31	961	Inquire*

**\*Note:** At time of publication, Type III was not released for sale. Please contact 3M Customer Service for current availability.

## BGA 0.65 mm Pitch Socket Available Package Guide Sizes

Socket Type	Series Number	Package Body Size (mm)	Matrix Count	Maximum Pin Count
I	9610	8x8	10x10	100
	9611	8x8	11x11	121
	9612	9x9	12x12	144
	9613	9x9	13x13	169
	9614	10x10	13x13	169
	9615	10x10	14x14	196
	9616	11x11	15x15	225
	9617	11x11	16x16	256
	9618	12x12	16x16	256
	9619	12x12	17x17	289
II	9671	9x9	13x13	169
	9620	13x13	18x18	324
	9621	13x13	19x19	361
	9670	13x13	20x20	400
	9622	14x14	19x19	361
	9623	14x14	20x20	400
	9625	15x15	20x20	400
	9624	15x15	21x21	441
	9672	15x15	22x22	484
	9626	16x16	22x22	484
	9627	16x16	23x23	529
9628	17x17	24x24	576	
9629	17x17	25x25	625	

**Note:** Contact 3M Customer Service Rep or 3M Authorized Distributor for information on sizes not listed on the above chart. Contact patterns can be customized to match the package.

# 3M™ Textool™ Open-Top BGA Sockets 0.80 mm



In an effort to better serve our customers, 3M continually updates our technical documents. Please visit our website for the most up-to-date technical information.

[www.3M.com/electronics](http://www.3M.com/electronics)

## BGA 0.80 mm Pitch Socket Platforms

Type	Maximum Body Size (mm)	Maximum Matrix	Maximum Ball Count	Status
I	12x12	13x13	169	Available
II	17x17	19x19	361	Available
III	21x21	25x25	625	Available
IV	24x24	31x31	961	Inquire*

## BGA 0.80 mm Pitch Socket Available Package Guide Sizes

Socket Type	Series Number	Package Body Size (mm)	Matrix Count	Maximum Pin Count	
I	9014	9x9	9x9	81	
	9015	9x9	10x10	100	
	9016	10x10	10x10	100	
	9017	10x10	11x11	121	
	9016	10x10	12x12	144	
	9018	11x11	11x11	121	
	9019	11x11	12x12	144	
	9018	11x11	13x13	169	
	9010	12x12	13x13	169	
	II	9026	12x12	14x14	196
9027		13x13	14x14	196	
9028		13x13	15x15	225	
9029		14x14	15x15	225	
9020		14x14	16x16	256	
9029		14x14	17x17	289	
9021		15x15	16x16	256	
9022		15x15	17x17	289	
9021		15x15	18x18	324	
9023		16x16	18x18	324	
9024		16x16	19x19	361	
9025		17x17	19x19	361	
III		9030	17x17	20x20	400
		9031	18x18	20x20	400
		9032	18x18	21x21	441
	9031	18x18	22x22	484	
	9033	19x19	21x21	441	
	9034	19x19	22x22	484	
	9033	19x19	23x23	529	
	9035	20x20	23x23	529	
	9036	20x20	24x24	576	
	9037	21x21	24x24	576	
	9038	21x21	25x25	625	

**Note:** Contact 3M Customer Service Rep or 3M Authorized Distributor for information on sizes not listed on the above chart. Contact patterns can be customized to match the package.

# 3M™ Textool™ Open-Top BGA Sockets 1.0 mm



In an effort to better serve our customers,  
3M continually updates our technical documents.  
Please visit our website for the most  
up-to-date technical information.

[www.3M.com/electronics](http://www.3M.com/electronics)

## BGA 1.0 mm Pitch Socket Platforms

Type	Maximum Body Size (mm)	Maximum Matrix	Maximum Ball Count	Status
0	19x19	17x17	289	Available
I	29x29	27x27	729	Available
II	40x40	39x39	1521	Available
III	45x45	45x45	2025	Available

## BGA 1.0 mm Pitch Socket Available Package Guide Sizes

Socket Type	Series Number	Package Body Size (mm)	Matrix Count	Maximum Pin Count
0	9342	6x6	6x6	36
	9348	11x11	10x10	100
	9340	12x10	10x8	80
	9300	12x12	11x11	121
	9301	13x13	11x11	121
	9302	13x13	12x12	144
	9303	14x14	12x12	144
	9304	14x14	13x13	169
	9305	15x15	13x13	169
	9306	15x15	14x14	196
	9307	17x17	15x15	225
	9308	17x17	16x16	256
	9344	18x12	16x10	160
	9343	18x18	15x15	225
9309	19x19	17x17	289	
I	9352	14x10	13x9	117
	9355	15x15	14x14	196
	9356	17x17	15x15	225
	9357	17x17	16x16	256
	9358	19x19	17x17	289
	9310	19x19	18x18	324
	9311	21x21	19x19	361
	9312	21x21	20x20	400
	9313	23x23	21x21	441
	9314	23x23	22x22	484
	9315	25x25	23x23	529
	9316	25x25	24x24	576
	9317	27x27	25x25	625
	9318	27x27	26x26	676
9319	29x29	27x27	729	
II	9360	29x29	28x28	784
	9320	31x31	29x29	841
	9321	31x31	30x30	900
	9322	33x33	31x31	961
	9323	33x33	32x32	1024
	9324	35x35	33x33	1089
	9325	35x35	34x34	1156
	9326	37.5x37.5	36x36	1296
	9327	37.5x37.5	37x37	1369
	9328	40x40	38x38	1444
	9329	40x40	39x39	1521
III	9331	42.5	41	1681
	9332	42.5	42	1764
	9333	45	43	1849
	9334	45	44	1936
	9335	47.5	45	2025

**Note:** Contact 3M Customer Service Rep or 3M Authorized Distributor for information on sizes not listed on the above chart. Contact patterns can be customized to match the package.

# 3M™ Textool™ Open-Top BGA Sockets 1.27 mm



In an effort to better serve our customers, 3M continually updates our technical documents. Please visit our website for the most up-to-date technical information.

[www.3M.com/electronics](http://www.3M.com/electronics)

## BGA 1.27 mm Pitch Socket Platforms

Type	Maximum Body Size (mm)	Maximum Matrix	Maximum Ball Count	Status
II	35x35	27x27	729	Available
III	45x45	35x35	1225	Available

**\*Note:** At time of publication, Type I was not released for sale. Please contact 3M Customer Service for current availability.

## BGA 1.27 mm Pitch Socket Available Package Guide

Socket Type	Series Number	Package Body Size (mm)	Matrix Count	Maximum Pin Count
II	9222	29 x 29	21 x 21	441
	9223	29 x 29	22 x 22	484
	9224	31 x 31	23 x 23	529
	9225	31 x 31	24 x 24	576
	9226	33 x 33	24 x 24	576
	9227	33 x 33	25 x 25	625
	9228	35 x 35	26 x 26	676
	9229	35 x 35	27 x 27	729
	III	9232	37.5 x 37.5	28 x 28
9233		37.5 x 37.5	29 x 29	841
9234		40 x 40	30 x 30	900
9235		40 x 40	31 x 31	961
9236		42.5 x 42.5	32 x 32	1024
9237		42.5 x 42.5	33 x 33	1089
9238		45 x 45	34 x 34	1156
9239		45 x 45	35 x 35	1225

**Note:** Contact 3M Customer Service Rep or 3M Authorized Distributor for information on sizes not listed on the above chart. Contact patterns can be customized to match the package.

.80 mm



Type II

.65 mm



Type II

1.00 mm



Type I

Type I



1.27 mm

Type II

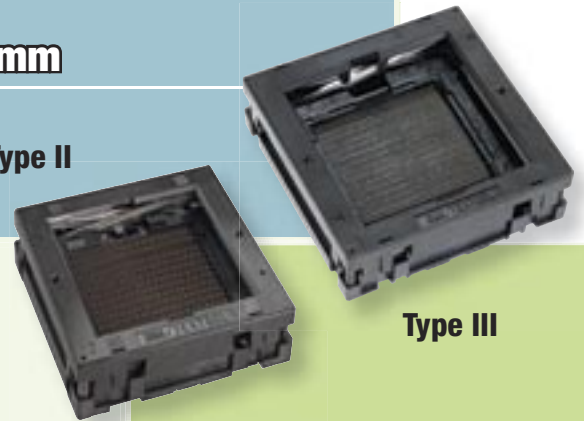

Type III

Type 0

Type II

Type III

3M and Textool are trademarks of 3M.

### Important Notice

All statements, technical information, and recommendations related to 3M's products are based on information believed to be reliable, but the accuracy or completeness is not guaranteed. Before using this product, you must evaluate it and determine if it is suitable for your intended application. You assume all risks and liability associated with such use. Any statements related to the product which are not contained in 3M's current publications, or any contrary statements contained on your purchase order shall have no force or effect unless expressly agreed upon, in writing, by an authorized officer of 3M.

### Warranty; Limited Remedy; Limited Liability.

This product will be free from defects in material and manufacture for a period of one year from the time of purchase. **3M MAKES NO OTHER WARRANTIES INCLUDING, BUT NOT LIMITED TO, ANY IMPLIED WARRANTY OF MERCHANTABILITY OR FITNESS FOR A PARTICULAR PURPOSE.** If this product is defective within the warranty period stated above, your exclusive remedy shall be, at 3M's option, to replace or repair the 3M product or refund the purchase price of the 3M product. **Except where prohibited by law, 3M will not be liable for any indirect, special, incidental or consequential loss or damage arising from this 3M product, regardless of the legal theory asserted.**



### Electronics

6801 River Place Blvd.  
Austin, TX 78726-9000  
www.3M.com/electronics  
1-800-225-5373  
1-800-932-9373 (fax)