

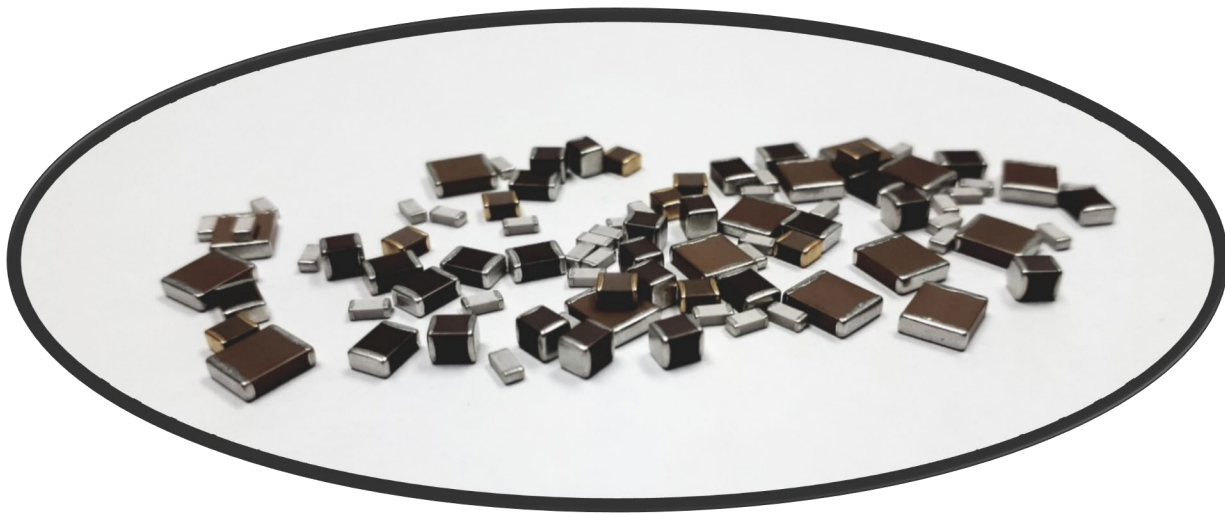

# Ceramics FAQ and Application Guide



## Disclaimer

This FAQ and Application Guide provides general information applicable to both **KEMET** and **YAGEO** brand multilayer ceramic capacitors (MLCCs). The content reflects the combined expertise, product capabilities, and best practices of the YAGEO Group's ceramic capacitor portfolio. All information in this document is for informational purposes only and is not considered a specification.

To submit a question, please go to <https://yageogroup.com/SalesResources/ContactUs>

Release Date: 11/15/25

Expiration Date: Six Months after release date. Please contact YAGEO Group sales for the most recent version.

## CONTENTS

<b>General</b> .....	5
What is Capacitance? .....	5
What is a Class I, Class II, and Class III Ceramic Capacitor? .....	7
What is the function of a capacitor in a circuit? .....	8
Do MLCCs Experience Outgassing?.....	9
How does KEMET Mitigate Sn (Tin) Whisker Growth in MLCCs? .....	9
How long can I store an MLCC? .....	9
Can MLCCs be used beyond their recommended storage life?.....	10
How long can MLCCs be stored ones mounted to a PCB?.....	10
What is the Coefficient of Thermal Expansion (CTE) for MLCCs?.....	10
Can I manually bend the leads of a leaded capacitor?.....	11
Where do I find typical piece weights for KEMET’s MLCCs? .....	11
Why does KEMET offer three gold plating thicknesses? .....	12
Does KEMET Offer SnPb Termination in Automotive Grades MLCCs?? .....	12
<b>Electrical Characteristics</b> .....	13
What is Insulation Resistance?.....	13
What is Impedance? .....	15
What is Dielectric Withstanding Voltage (DWV)?.....	17
What is Aging for MLCCs?.....	18
What is Dielectric Absorption? .....	21
What causes acoustic noise in MLCCs? .....	22
What is Equivalent Series Resistance (ESR)? .....	23
What is Dissipation Factor (DF)? .....	25
What is Equivalent Series Inductance (ESL)?.....	26
What is Series Resonant Frequency (SRF)? .....	27
Why does capacitance change with DC voltage? .....	28
Why does capacitance appear to be out of tolerance when I measure it?.....	31
What are the main differences between BME and PME? .....	34
<b>Mounting and Handling</b> .....	34
What is KEMET's recommended solder reflow profile? .....	34
Is it OK to hand solder MLCCs using a soldering iron? .....	36
What is the recommended cleaning procedure for MLCCs after mounting? .....	36
Can MLCCs be reworked after mounting? .....	38
Do Ceramic Capacitors have an MSL Rating?.....	39

How Long can MLCCs be stored once soldered to a PCB? .....	39
What is the recommended solder fillet height for a KONNEKT Stack in the standard orientation? .....	40
What is the recommended solder fillet height for a KONNEKT Stack in a Low-Loss orientation? .....	40
What is the recommended solder fillet height of an MLCC? .....	41
<b>Flex Mitigation</b> .....	41
How do I reduce the chances of failures due to flex cracks?.....	41
How does Flexible Termination reduce the risk of flex cracks? .....	43
Does a Flex Crack always have the same crack signature? .....	44
Do flex cracks always result in immediate short circuits? .....	44
Does KEMET ever ship capacitors with flex cracks, while still in the tape & reel?.....	44
<b>High Voltage</b> .....	45
What is ArcShield™ Technology? .....	45
What is the difference between Creepage vs Clearance? .....	45
How do I reduce the risk of arcing in high voltage applications? .....	46
<b>Electrostatic Discharge (ESD) Rated MLCCs</b> .....	48
What is ESD? .....	48
How Does KEMET Test MLCCs for ESD Susceptibility? .....	48
Does KEMET Offer MLCCs with an ESD Rating? .....	49
Why are MLCCs used for ESD Suppression?.....	50
<b>DC and AC Voltage Considerations</b> .....	52
What is the maximum AC voltage I can use on a DC rated MLCC? .....	52
Is it safe to use ceramic capacitors above their rated voltage?.....	54
Do KEMET ceramic capacitors require voltage derating? .....	54
<b>Safety Certified Ceramic Capacitors</b> .....	55
Where can I find safety certificates for KEMET products? Can I obtain a CB report?.....	55
Can a Y2 capacitor be used in place of a Y1? .....	56
Can safety certified capacitors be used in DC voltages? .....	57
Can safety certified capacitors be used above their rated voltage?.....	57
Is the moisture sensitivity level different for Safety Certified disc products compared to SMD? .....	57
<b>HiQ High Frequency RF Capacitors (CBR Series)</b> .....	58
What does RF Stand For? .....	58
What is an RF Capacitor? .....	58
What are typical applications for RF capacitors?.....	59
What is the difference between standard Ceramic Capacitors and HiQ RF capacitors?.....	60
What makes KEMET’s CBR Automotive Grade RF capacitors automotive grade? .....	61

What is Q or Quality Factor and how does it relate to Dissipation Factor?.....	61
What are S-Parameters and how do I obtain them? .....	62
Do I need to be concerned with PCB and pad dimensions when using RF capacitors? .....	63
What are Modelithics Models and how do I obtain them? .....	64
<b>KONNEKT Technology</b> .....	65
What is KONNEKT™ Technology? .....	65
Is KONNEKT™ Technology Pb-Free and RoHS Compliant? .....	66
Why does KONNEKT™ use TLPS and not metal frames?.....	66
What is the difference between Standard and Low-Loss orientation? .....	67
Why are some KONNEKT capacitors available in standard orientation but not Low Loss? .....	68
Is there a difference between the materials or construction of standard orientation KONNEKT capacitors versus Low-Loss orientation?.....	68
What are the recommended soldering techniques for KONNEKT capacitors? .....	69
How are KONNEKT capacitors tested for vibration?.....	69
<b>Reliability and Qualification</b> .....	69
Where do I find KEMET's Quality Documents and Certificates? .....	69
Where can I find Qualification Reports for Ceramic Capacitors? .....	69
<b>Simulation (KSIM) and Testing</b> .....	70
Does KEMET offer a tool to simulate electrical performance of MLCCs? .....	70
Are S-Parameters available for KEMET's MLCCs? .....	70
After simulating a part in KSIM, how do I get samples?.....	71
What do I do if a part number is not available in KSIM?.....	72
<b>Material Compliance</b> .....	72
Do KEMET Ceramic Capacitors Contain PFAS? .....	72
Where do I find information on Material Compliance?.....	72

## General

### What is Capacitance?

Key Words: Capacitance, capacitors, farads

**Capacitance** is a measure of the ability of an object to store electric charge. It is measured in the SI unit Farad as a ratio between electrical charge and electrical potential. Capacitance is calculated using the following equation:

$$C = \frac{q}{V}$$

Where:

- q is the charge held – Measured in coulombs (c)
- V is the electric potential (voltage), which can be derived in each application from the following equation:

$$V = \frac{1}{4\pi\epsilon_0} \int \frac{\sigma}{r} dS$$

Where:

- $\sigma$  is the surface charge density
- dS is the integrated element of area on the surface of the conductor
- r is the length from dS to a fixed point
- $\epsilon_0$  is the vacuum permittivity

Capacitance is utilized in electrical circuits to store and discharge electrical current in controlled ways. Capacitance can be divided into **Self Capacitance** & **Mutual Capacitance**. Every conductor exhibits capacitance, this is known as Self Capacitance, or the amount of electric charge that must be added to raise the electric potential by 1 volt.

**Mutual Capacitance** is the capacitance between two conductive surfaces. An often-used example is a parallel-plate capacitor. This is made up of two conductive plates, with an insulating dielectric material between them. A parallel plates' capacitance is calculated using the following equation:

$$C = \epsilon \frac{A}{d} \quad \& \quad \epsilon = \epsilon_0 \epsilon_r$$

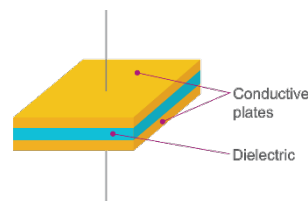

Where:

- C is the capacitance in farads
- A is the area of the conductive parallel plates in square meters
- $\epsilon_0$  is the electric constant vacuum permittivity ( $\epsilon_0 \approx 8.854 \times 10^{-12} \text{ F}\cdot\text{m}^{-1}$ )
- $\epsilon_r$  is the relative permittivity (dielectric constant) of the dielectric material
- d is the distance between the two plates

## Calculating the capacitance of an MLCC

The mutual capacitance equation shown above, calculates the capacitance for a single layer, parallel plate capacitor. MLCCs, Multi-layer Ceramic Capacitors, use a similar equation to calculate their capacitance. See equation below.

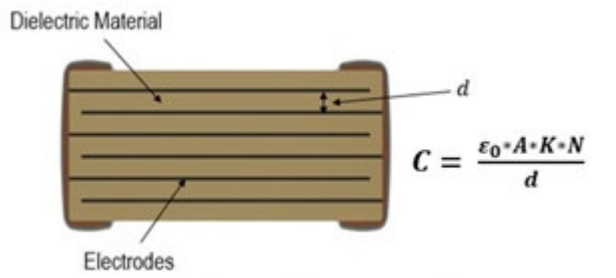

Where:

- $\epsilon_0$  is the electric constant vacuum permittivity ( $\epsilon_0 \approx 8.854 \times 10^{-12} \text{ F}\cdot\text{m}^{-1}$ )
- A is the active area of the electrodes
- K is the relative dielectric permittivity of the ceramic material (dielectric constant  $\epsilon_r$ )
- N is the number of electrodes (or plates in our mutual capacitance example)
- d is the dielectric thickness (distance between electrodes)

As seen above, the equation from a parallel plate capacitor and an MLCC are very similar, with the addition of the variable N in the MLCC equation. This variable accounts for the multiple layers of electrodes in the device and is directly proportional to the total capacitance.

## What is a Class I, Class II, and Class III Ceramic Capacitor?

Key Words: Class I, Class II, Class III, Temperature Coefficient

Ceramic Capacitors are categorized into three classes based on their temperature coefficient of capacitance (TCC). The Electronic Industries Alliance standard EIA-198 defines an alpha numeric system to categorize the wide variety of dielectrics based on temperature coefficients. A Class I capacitor retains a stable capacitance over the rated temperature and the capacitance change is specified in ppm/°C. Class II & Class III are considered temperature sensitive, and the capacitance change is specified in percent. To identify a dielectric, use the following tables outlining Class I, II, and III.

Class I Dielectrics (Examples: C0G, U2J, X8G)

Alpha Symbol	Significant Figure of Temp Coefficient ppm/°C	Numerical Symbol	Multiplier to significant figure	Alpha Symbol	Tolerance of Temp Coefficient ± ppm/°C
C	0	0	-1	G	30
B	0.3	1	-10	H	60
L	0.8	2	-100	J	120
A	0.9	3	-1000	K	250
M	1.0	4	-10000	L	500
P	1.5	5	+1	M	1000
R	2.2	6	+10	N	2500
S	3.3	7	+100		
T	4.7	8	+1000		
U	7.5	9	+10000		

Temperature Range -55 °C to +125 °C

A C0G capacitor has ±30PPM/°C change in capacitance over a temperature range of -55 to +125°C. By using the above table, we can derive that value by plugging in the **significant figure temperature coefficient**, the **significant figure**, and **temperature coefficient** as shown below.

$$0 \times -1 = 0 \pm 30\text{ppm}/^{\circ}\text{C} \rightarrow \text{COG}$$

$0 \pm 30\text{ppm}/^{\circ}\text{C} \rightarrow \pm 0.3\% @ 125^{\circ}\text{C}$

Class II & Class III Dielectrics (Examples: X7R, X5R, X8R)

Alpha Symbol	Low Temperature (°C)	Numerical Symbol	High Temperature (°C)	Alpha Symbol	Max cap change over temp. range (%)
Z	+10	2	+45	A	±1.0
Y	-30	4	+65	B	±1.5
X	-55	5	+85	C	±2.2
		6	+105	D	±3.3
		7	+125	E	±4.7
		8	+150	F	±7.5
		9	+200	P	±10
				R	±15
				S	±22
				* L	+15 to - 40
				T	+22 to - 33
				U	+22 to - 56
				V	+22 to - 82

\* Industry Classification (Non EIA-198)

A X7R capacitor has ±15%/°C change in capacitance over a temperature range of -55 to +125°C. By using the above table, we can derive that value by plugging in the **low temperature**, **the high temperature**, and **the max cap change over range** as shown below.

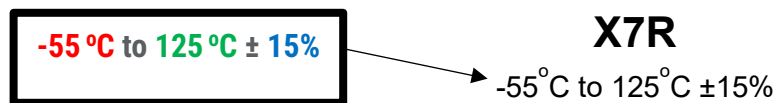

## What is the function of a capacitor in a circuit?

Key Words: Capacitor, Function

A capacitor is a crucial component in electrical circuits with several key functions:

- **Energy Storage:** Capacitors temporarily store electrical energy and release it as required, aiding in the stabilization of power supply fluctuations.
- **Filtering:** They serve to filter out electrical noise and smooth the output of power supplies, ensuring a consistent voltage level.
- **Timing:** Capacitors are integral to timing circuits, where their charge and discharge rates are utilized to control the timing of various events.
- **Coupling and Decoupling:** They facilitate the passage of alternating current (AC) signals while blocking direct current (DC) signals, which is crucial in signal processing and communication circuits.
- **Tuning:** In radio frequency applications, capacitors are employed to tune circuits to specific frequencies

## Do MLCCs Experience Outgassing?

Key Words: Outgassing

KEMET's Surface Mount Device (SMD) Multilayer Ceramic Capacitors (MLCCs) are constructed using high temperature sintering processes in excess of 1100°C-1200°C such that the final product experiences no outgassing. Although there are specifications for testing for outgassing, the current military standards for MLCCs used in space applications do not require this test. Therefore, KEMET deems it unnecessary to perform outgassing tests on MLCCs.

Note: The statement above applies to BME MLCC with sintered copper terminations. In case of flexible termination products, a cured silver-based soft-termination layer is applied on the copper terminations of the chips and subsequently plated with Pb-Sn or other finishes to provide additional performance benefits in board flex situations. This soft-termination is adequately cured and is not expected to outgas, however, YAGEO Group does not have testing data to support this.

## How does YAGEO Group Mitigate Sn (Tin) Whisker Growth in MLCCs?

Key Words: Tin Whiskers

Users of MLCCs with pure tin terminations have long been concerned with possible tin whisker growth under certain application conditions. Over time, improvements in materials and processing have been employed that dramatically reduces tin whisker growth:

- YAGEO Group uses a matte tin finish for the plating of the termination. The matte finish does not contain any brighteners which are known to cause tin whisker growth.
- All MLCCs with tin finish contain a Nickel underlayer which acts as a stress relief for the tin. This underlayer reduces the ability for tin whiskers to grow.
- YAGEO Group's plating process uses a smaller grain size and slower deposition rate which reduces the stress on the termination and thus helps mitigate tin whisker growth.
- During the plating process, each MLCC will go through a 150°C drying process for 60 minutes which will anneal the termination. This "annealing" process will reduce the stress on the termination thus reducing the risk of tin whisker growth.

## How long can I store an MLCC?

Key Words: Storage life, oxidation

YAGEO Group Ceramic chip capacitors should be stored in normal working environments. While the chips themselves are quite robust in other environments, solderability will be degraded by exposure to high temperatures, high humidity, corrosive atmospheres, and long-term storage. In addition, packaging materials will be degraded by high temperature reels may soften, or warp and tape peel force may increase.

YAGEO Group recommends that maximum storage temperature not exceed 40°C and maximum storage humidity not exceed 70% relative humidity. Temperature fluctuations should be minimized to avoid condensation on the parts and atmospheres should be free of chlorine and sulfur bearing compounds. For optimized solderability chip stock should be used promptly, preferably within 1.5 years of receipt.

Note: The storage life of an MLCC only impacts the solderability of the terminations and not the electrical and mechanical performance.

## Can MLCCs be used beyond their recommended storage life?

It is recommended that the MLCCs be used within their recommended storage life as specified in the datasheet. Since storage life only impacts the solderability of the MLCCs, if this time is exceeded, it is up to the customer to validate solderability before use.

## How long can MLCCs be stored ones mounted to a PCB?

MLCCs mounted to PCBs are no longer impacted by solderability. Therefore, after board assembly, the recommended storage conditions are according to dielectric operational temperature range to avoid any degradation in performance. Under these conditions, the mounted MLCCs can be stored indefinitely.

<b>Dielectric</b>	<b>Temperature Range</b>
X7R	-55°C to +125°C
C0G	-55°C to +125°C
U2J	-55°C to +125°C
X5R	-55°C to +85°C
Z5U	+10°C to +85°C
Y5V	-30°C to +85°C

## What is the Coefficient of Thermal Expansion (CTE) for MLCCs?

Key Words: Coefficient of Thermal Expansion, CTE

The coefficient of thermal expansion (CTE) refers to the rate at which a material expands with increase in temperature.

The below table shows the typical value range for Class I, Class II, & Class III MLCCs.

<b>Dielectric</b>	<b>CTE (ppm/°C)</b>
Class III	11 - 12
Class II BaTiO <sub>3</sub>	10 - 11
Class I CaZrO <sub>3</sub>	9 - 10

## Can I manually bend the leads of a leaded capacitor?

If it is necessary to bend leads for axial or radial molded components, care must be taken to prevent damage of the molding compound or lead. Failure to follow guidelines may effect solderability of component or long term reliability under operation.

- Leads should be clamped with enough force to properly bend the lead but not to damage plating of lead.
- Clamp should not come into contact with molding.
- Distance between the clamp and the molding should be greater than the lead diameter.
- Bending radius should always be greater than the lead diameter.
- Never bend leads more than 90 degrees.
- Never bend leads more than one time as to not anneal the material

## Where do I find typical piece weights for KEMET’s MLCCs?

Typical piece weight can be found on KEMET’s detailed specification sheets. See below for example.

General Information	
Series	SMD Auto X7R
Style	SMD Chip
Description	SMD, MLCC, Temperature Stable, Automotive Grade
Features	Temperature Stable, Automotive Grade
RoHS	Yes
Termination	Tin
Marking	No
Qualifications	AEC-Q200
AEC-Q200	Yes
Component Weight	11 mg
Shelf Life	78 Weeks
MSL	1

## Why does KEMET offer three gold plating thicknesses?

High Temperature KEMET’s Surface Mount Device (SMD) Multilayer Ceramic Capacitors (MLCCs) are specifically designed for applications in harsh environmental applications such as down hole oil exploration, industrial high temperature electronics, geothermal, and aerospace which requires capacitors that are robust and reliable at extreme temperatures. KEMET offers three different gold plating thicknesses depending on the final application. See table below.

Gold plating thickness	Termination finish KEMET internal character	Applications
1.97 – 11.8 µin	E	Immersion gold. Typically used for solder reflow and epoxy bonding attachment. Target applications include extreme environments such as downhole exploration. Also used as an alternative to a Silver (Ag) termination.
30 – 70 µin	F	Electroplated Gold. Typically used for IR Reflow and wire bonding attachment. Target applications include downhole and aerospace. Also used as a whisker-free alternative to pure tin (Sn).
100 µin minimum	G	Electroplated thick Gold. Typically used for long term storage and is usually solder dipped before use or attached with epoxy. Target applications are extreme environments such aerospace applications.

## Does KEMET Offer SnPb Termination in Automotive Grades MLCCs??

The Automotive industry has moved to complete RoHS and Reach compliance for many years which excludes the use of SnPb terminations for Automotive applications. MLCCs with SnPb terminations are not RoHS or Reach compliant. In addition, all Automotive grade MLCC go through a custom automotive end of line test prior to shipment. Restricting these MLCCs to Sn terminations only prevents various processes from being contaminated with Pb and affecting Pb-Free MLCCs. KEMET recommends customers interested in SnPb terminations refer to the COTS series which is available in both Sn and SnPb termination options.

[COG Dielectric \(COTS\) 10 – 250 VDC](#)

[X7R Dielectric \(COTS\) 6.3 – 250 VDC](#)

## Electrical Characteristics

### What is Insulation Resistance?

Insulation Resistance ( $R_{Ins}$ ) is defined as the ratio of the applied DC voltage across an MLCC and the resulting leakage current after a specific length of time. Ideal capacitors will theoretically have a perfect insulating dielectric material and thus will have no leakage current (infinite insulation resistance) with DC voltage. However, real MLCCs will have imperfect dielectric materials resulting in a measurable insulation resistance and leakage current.

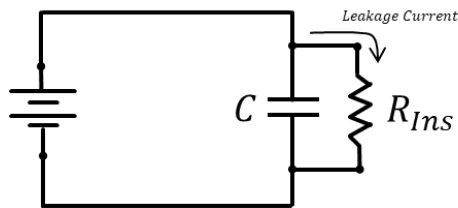

$$R_{Ins} = \frac{V_{dc}}{\text{Leakage Current}}$$

DC current through a capacitor can be separated into three regions: 1) Charging Current, 2) Absorption Current, and 3) Leakage Current. When voltage is applied to a capacitor, the initial inrush current will be due to the charging of the capacitor. Once the capacitor is fully charged, it will enter the absorption current region which is due to ferroelectric behavior of the MLCC and the effects of polarization. Eventually, the current will reach a steady state condition where it will be constant versus time and thus is called the leakage current. The leakage current can then be used to calculate the insulation resistance of the MLCC by the equation above.

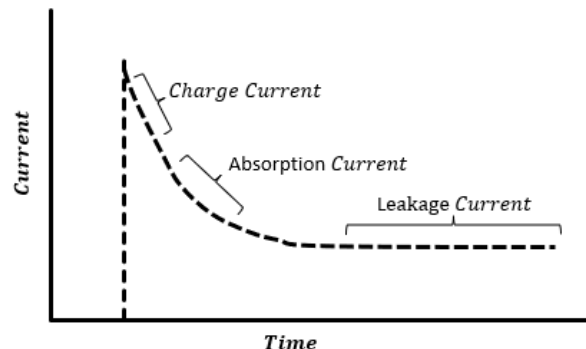

### Measuring Insulation Resistance of MLCCs

MLCCs typically have very high insulation resistances and therefore must be measured using equipment and fixtures that can accurately measure very low leakage currents. For lower capacitance MLCCs with insulation resistance in the Tera-ohm range, special fixturing and cables may be required to obtain accurate readings. Insulation resistance measurements shall be made between the capacitor terminals on a megohm-meter or an insulation resistance test set. Measurements are made immediately after a 2-minute period (KEMET) or a 1-minute period (YAGEO) of uninterrupted test voltage application and a charging current limited to 50 mA using the following measurement conditions:

Rated Voltage	Test voltage	Charge Time	Temperature
≤ 500 VDC	Rated voltage	120 ±5 s	25°C
> 500 VDC	500 VDC	120 ±5 s	25°C

### Specification for Insulation Resistance

Typical insulation resistance values for MLCCs can range from Mega-ohms to 10s of Tera-ohms depending on the capacitance, dielectric material, internal design, applied voltage, and temperature.

YAGEO Group's series datasheets provide specifications for the insulation resistance limit based on the case size and capacitance value. This limit is typically provided as a value in MΩ-μF units and is usually between 100 MΩ-μF and 1000 MΩ-μF depending on the series and part type.

To determine the insulation resistance limit for a specific part, divide the MΩ-μF value by the capacitance in microfarads and compare to the maximum insulation resistance limit in the datasheet (typically 10GΩ). Then select the lower of the two limits, For example: Part Number: C1812V334KCRCTU (Commercial, X7R, 1812, 0.33 μF, 500 V)

- 1) From the KEMET HV X7R Commercial datasheet, select the limit according to the case size and capacitance value. For this part number, the insulation resistance limit will be 100 MW-mF or 10 GW, whichever is greater.

EIA Case Size	1,000 Megohm Microfarads or 100 GΩ	100 Megohm Microfarads or 10 GΩ
0603	N/A	All
0805	< 0.0039 μF	≥ 0.0039 μF
1206	< 0.012 μF	≥ 0.012 μF
1210	< 0.033 μF	≥ 0.033 μF
1808	< 0.018 μF	≥ 0.018 μF
1812	< 0.027 μF	≥ 0.027 μF
1825	< 0.120 μF	≥ 0.120 μF
2220	< 0.150 μF	≥ 0.150 μF
2225	< 0.180 μF	≥ 0.180 μF

- 2) Divide MΩ-μF value by the capacitance value in μF.

$$R_{Ins} \text{ Limit} = \min \left( 10,000 \text{ M}\Omega \text{ or } \frac{100 \text{ M}\Omega - \mu\text{F}}{0.33 \mu\text{F}} \right)$$

$$R_{Ins} \text{ Limit} = \min(10,000 \text{ M}\Omega \text{ or } 303 \text{ M}\Omega)$$

- 3) Select the lower of the two limits.

$$R_{Ins} \text{ Limit} = 303 \text{ M}\Omega$$

To avoid having to look up the insulation resistance limit in MΩ-μF and perform this calculation, YAGEO Group provides the insulation resistance limit on the individual specification sheet. See below example.

Specifications	
Capacitance	0.33 uF
Measurement Condition	1 kHz 1.0Vrms
Capacitance Tolerance	10%
Voltage DC	500 VDC
Dielectric Withstanding Voltage	750 VDC
Temperature Range	-55/+125°C
Temperature Coefficient	X7R
Capacitance Change with Reference to +25°C and 0 VDC Applied (TCC)	15%, 1kHz 1.0Vrms
Dissipation Factor	2.5% 1 kHz 1.0Vrms
Aging Rate	3% Loss/Decade Hour: Referee Time is 1000 Hours
Insulation Resistance	303 MOhms

## What is Impedance?

Impedance is a measure of how circuit elements resist the flow of alternating current (AC). It can be compared to resistance in a DC circuit, but also accounts for the capacitive and inductive components of an element. The capacitive and inductive components vary with a function of frequency, depending on the element. Impedance is a complex number typically represented as the following:

$$|Z| = R + jX$$

Where:

- $|Z|$  is the complex impedance value (measured in ohms)
- $R$  is the equivalent series resistance (ESR), representing a real number in ohms
- $X$  is the reactance (imaginary part), measured in ohms
- $j$  is an imaginary unit ( $j^2 = -1$ )

## Ideal Capacitor Impedance

For an ideal capacitor, the impedance is purely reactive (no real part), and is given by the equation:

$$|Z_c| = \frac{1}{j\omega C}$$

Where:

- $|Z_c|$  is the impedance of the capacitor
- $\omega = 2\pi f$  is the angular frequency (in radians per second)
- $f$  is the frequency of the AC signal (Hz)
- $C$  is the capacitance (in farads)

In this ideal case, the impedance of a capacitor is inversely related to the frequency applied as shown in the chart below:

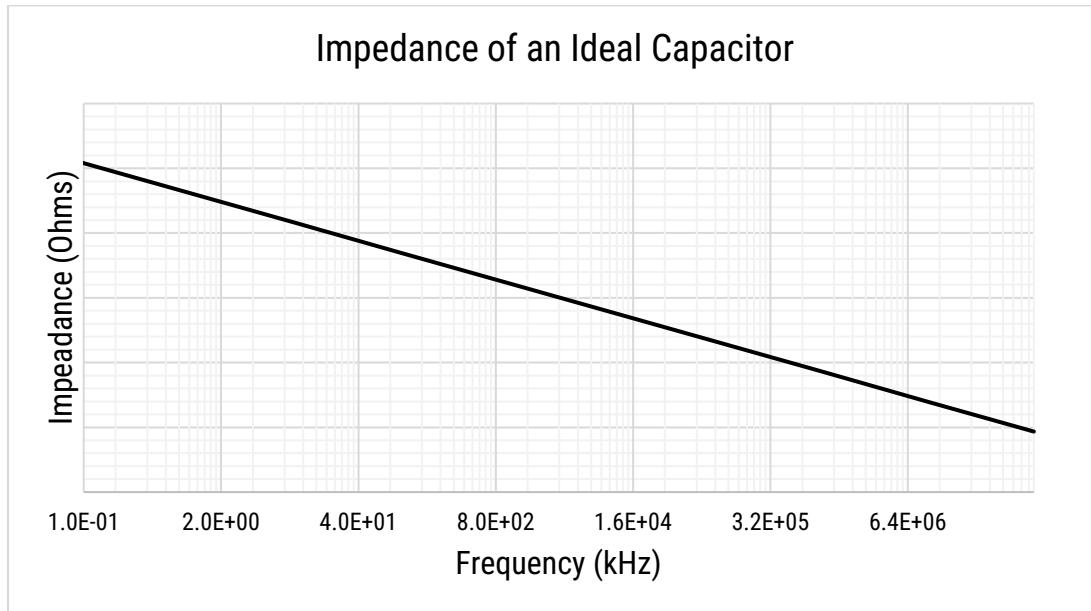

## Actual Capacitor Impedance

In a real capacitor, however, there is parasitic resistance (ESR) and inductance (ESL) due to losses from the electrodes and the dielectric material. To calculate this value, the equation and model gain complexity as shown below:



$$|Z| = \sqrt{ESR^2 + (X_L - X_C)^2}$$

$$X_C = j \frac{1}{\omega C}$$

$$X_L = j\omega ESL$$

Where:

- $|Z|$  is the impedance of the capacitor
- ESR is the equivalent series resistance of the capacitor
- $X_L$  is the parasitic inductance at a given frequency
- $X_C$  is the capacitance at a given frequency

By applying these equations to our model, the shape of the impedance plot changes as shown below in the 10pF MLCC example:

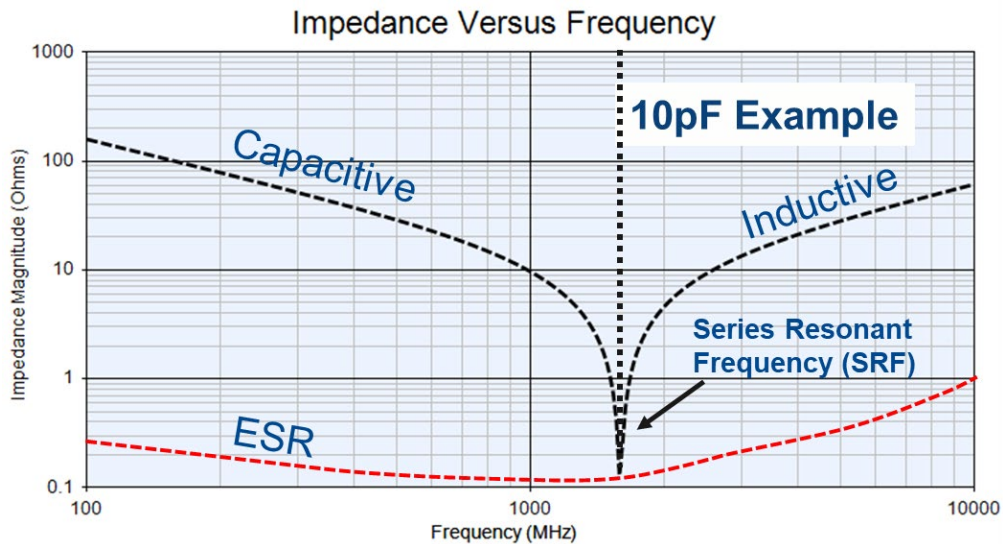

## What is Dielectric Withstanding Voltage (DWV)?

Dielectric Withstanding Voltage (DWV) refers to the ability of an MLCC to survive an overvoltage above its rated voltage for a short period of time. Another commonly used term for DWV is Voltage Proof. YAGEO Group designs MLCCs to have a dielectric withstanding voltage capability between 1.2 to 2.5 times the rated voltage.

For example, KEMET's X7R 0805 10nF 50V Commercial Grade MLCC has a DWV 2.5 times the rated voltage which is 125V. Per the specification, the capacitor is designed to survive an overvoltage up to 125V for no more than 5 seconds with a charging current not exceeding 50mA.

However, DWV is an indication of the overvoltage performance of an MLCC and is not meant to allow voltages higher than the rated voltage in an application. In other words, YAGEO Group does not recommend exceeding the rated voltage per the specification sheet, even for a short duration of time.

Since the actual DWV value depends on the rated voltage, see the individual specification sheet. Example below.

Specifications	
Capacitance	0.01 uF
Measurement Condition	1 kHz 1.0Vrms
Capacitance Tolerance	10%
Voltage DC	50 VDC
Dielectric Withstanding Voltage	125 VDC
Temperature Range	-55/+125°C
Temperature Coefficient	X7R
Capacitance Change with Reference to +25°C and 0 VDC Applied (TCC)	15%, 1kHz 1.0Vrms
Dissipation Factor	2.5% 1 kHz 1.0Vrms
Aging Rate	3% Loss/Decade Hour: Referee Time is 48 Hours
Insulation Resistance	100 GOhms

## What is Aging for MLCCs?

Aging is a phenomenon where the capacitance of a Class II and Class III MLCC will decrease over time. MLCC aging is only related to a change in capacitance over time and is not related in any way to the lifetime or reliability of the MLCC.

### What Causes Aging

MLCCs are constructed using alternating layers of ceramic dielectric and metal electrodes. Figure 1 shows the calculation of capacitance for an MLCC where the A is the active area of the electrodes, K is the relative dielectric permittivity, N is the number of electrodes and d is the dielectric thickness. By increasing either A, K, or N, the net result will be an increase in capacitance.

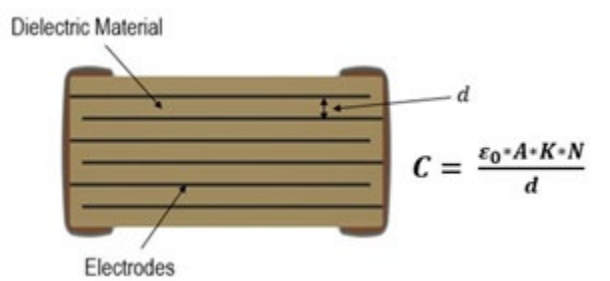

Class II MLCCs are made from a ( $\text{BaTiO}_3$ ) ferroelectric material which has a crystalline structure containing Barium, Titanian, and Oxygen atoms. Above its curie point ( $\sim 125^\circ\text{C}$ )  $\text{BaTiO}_3$  has a cubic crystal structure but as it cools down below its curie point, it transitions into a tetragonal shape. See Figure 3. The effect is an immediate spontaneous polarization of the material, forming dipoles which arrange into domain regions. The creation of the dipole is due to the shift of the titanium ion within the crystal lattice structure causing an electric field to exist. The arrangement of the domain regions within the dielectric are randomly scattered throughout the material in which there is no net electric polarization of the material. The electric fields of each of the dipoles cancel each other out into a neutral state. The result of the spontaneous polarization of the material is a high permittivity which gives Class II and III MLCCs their high capacitance.

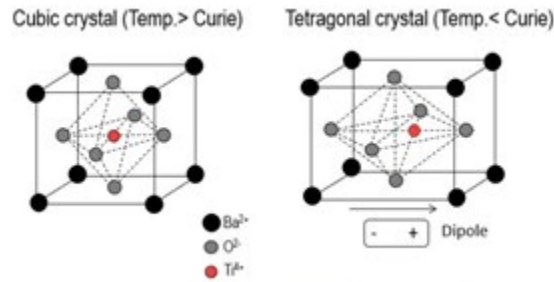

Immediately after spontaneous polarization occurs, the domains will begin to relax and realign within the material causing a gradual decrease in the relative permittivity. The effect is a loss of capacitance over time which is normally expressed as % Capacitance change per decade-hour after the last heat above curie point.

For Class II and Class III capacitors, KEMET provides Aging rate and Referee times in the part number specification sheet for all KEMET part numbers. The below table provides typical aging rates and referee times for MLCCs. Aging rates are expressed in percent and specify the amount capacitance loss per decade-hour indefinitely. Referee time refers to the number of hours after the last heat where the capacitance is stated to be within specification. For example, for a 10uF ±5% tolerance MLCC with a referee time of 1000 hours, this means the MLCC will be within tolerance at 1000 hours after the last heat above the curie point. This is typically when the MLCCs are soldered to the PCB.

EIA Code	Typical aging (%/decade hrs.)	Typical referee time (hrs.)
C0G	0%	N/A
X7R	3%	1,000
X5R	5%	48

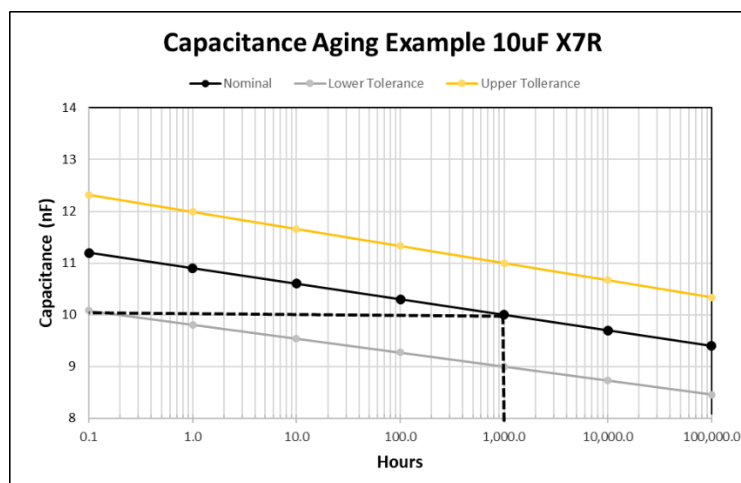

Typical Aging Rates. See Part Number Specification Sheet for actual aging rate and referee time

Special Note: Measurements before or after the referee time can show a capacitance out of specification. This is especially noticeable if measuring capacitance immediately after a soldering process. However, it is not necessary to wait until the referee time to measure the capacitance.

## Calculating Aging Rate

By using the aging rate equation below, users can calculate the “aged” capacitance (C), based on the nominal capacitance (Cr), aging rate (A), referee time (tr), and time after last heat (t).

$$C = C_r \left[ 1 - \left( \left( \frac{A}{100} \right) \cdot \log_{10} \frac{t}{t_r} \right) \right]$$

## Can Capacitor Aging be Reset?

Yes, since Class II MLCCs are ferroelectric, once they are subjected to a temperature above the curie point, they will “deage” and the aging process will start again at 0 hours

## What is Dielectric Absorption?

In certain circuits, the capacitor's dielectric absorption is an important parameter. Dielectric absorption is the property of a dielectric, which prevents a capacitor from totally discharging, even when short-circuited for a short period of time. When the short circuit is removed, a small amount of D.C. voltage gradually reappears at the capacitor's terminals. Dielectric absorption is primarily a consideration for film capacitors in precision integrators or sample/hold circuits. It tends to increase as the dielectric constant ("K") increases. Dielectric absorption is not normally specified nor measured for ceramic capacitors. Dielectric absorption may be a larger consideration for low voltage (thin dielectric) ceramic capacitors than for larger voltages.

### Measurement Method

1. Short circuit the capacitors for 4 - 24 hours.
2. Charge the capacitors to rated voltage.
3. Discharge the capacitors for 5 - 10 seconds through a 5-ohm resistor.
4. Measure the maximum recovery voltage over an interval of 1 - 10 minutes, using an electrometer with an input impedance  $\geq 10^{10}$ .
5. Calculate dielectric absorption recovery voltage as a percentage of the charging voltage.

Dielectric	Dielectric Absorption
Class 1: C0G/NP0	~0.5%
Class 2 & 3: X7R, X5R, Z5U	1.0%-1.8%

Typical Dielectric Absorption for MLCCs

## What causes acoustic noise in MLCCs?

Key Words: Acoustic Noise, Buzzing, piezoelectric effect

Class II and Class III MLCCs have a phenomenon called the piezoelectric effect that can cause “singing” or audible hum. This hum is caused by physical vibrations in the capacitor as it is mounted onto a PCB. Ferroelectric capacitors (Class II & III) produce acoustic noise under specific conditions that directly correlate with the design of the capacitor and AC voltage. When we apply an electric field to Barium Titanate, the titanium ion will shift within the crystal structure as shown in the diagram below. This causes mechanical distortion, changing the part geometry.

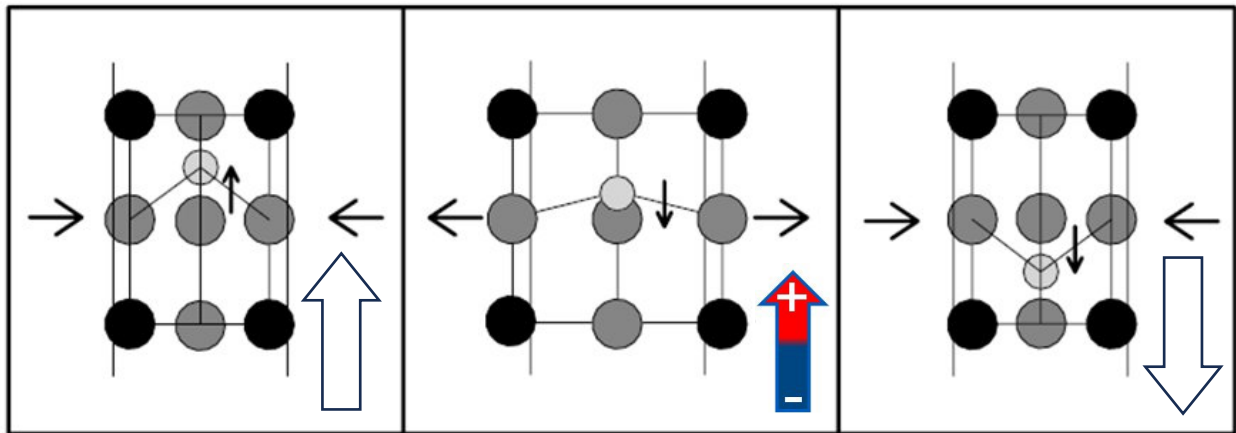

The dielectric constant, and all the physical parameters (case size, number of layers, etc) play a role in the exact frequency that the acoustic noise occurs, as well as the external factors of application voltage and AC voltage.

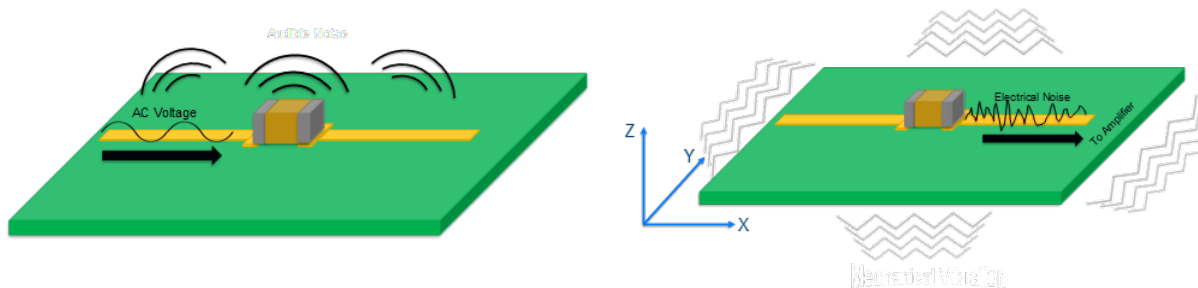

Here are 4 mitigation techniques that can be applied to reduce acoustic noise in an MLCC:

1. Change to a Class I (COG) Dielectric – Class I dielectrics are not ferroelectric, so they are not susceptible to the piezoelectric effect.
2. Reduce the AC voltage applied to the capacitor – By reducing the voltage applied, the vibrations will not be as large and may not be audible.
3. Adjust the AC voltage frequency applied to the capacitor – By changing the frequency applied to the capacitor, an engineer could effectively push the noise out of the audible range.
4. Change product to a KPS Stack. – KPS stacks utilize the lead frame to absorb vibrations, causing less sound pressure to occur.

## What is Equivalent Series Resistance (ESR)?

Equivalent Series Resistance, or ESR is the sum of all the resistive losses in and MLCC and represents the real part of the complex impedance equation as seen below. This includes the losses due to the dielectric, internal electrodes, and external terminations. For MLCCs, the majority of the resistive losses are due to the dielectric and internal electrodes. At low frequencies, the dielectric losses dominate and decreases as frequency increases. At higher frequencies, the electrode losses dominate and increase as frequency increases. In general, MLCCs have very low ESR compared to other capacitor technologies making them a popular choice for AC applications.

$$Z = \sqrt{ESR^2 + (X_L - X_C)^2}$$



$$X_L = j\omega ESL$$

$$X_C = j \frac{1}{\omega C}$$

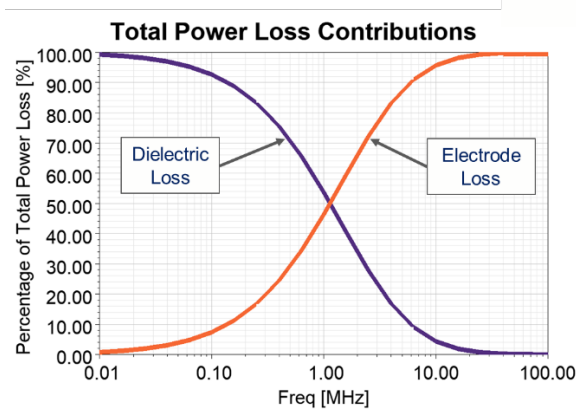

Figure 1 – Power loss contribution for dielectric and electrodes vs frequency

ESR is an important characteristic in MLCCs since high ESR can cause excessive power loss which can result in thermal runaway. Since the power dissipated in an MLCC is a product of the ESR and the square of the current, higher current applications can easily cause self-heating of the MLCC.

$$P = I^2 ESR$$

$$T_{rise} = P \cdot R_{\theta}$$

$R_{\theta}$  = Thermal Resistance of MLCC  
 $P$  = Dissipated Power (Heat)  
 $T_{rise}$  = Self temperature rise of MLCC

Class 1 MLCCs such as C0G and U2J utilize a low-loss dielectric and therefore have much lower ESR compared to Class 2 MLCCs such as X7R, X5R, etc. Due to having such low ESR, Class 1 MLCCs are ideal for high AC current applications such as DC-LINK, LLC resonant converters and wireless power transfer.

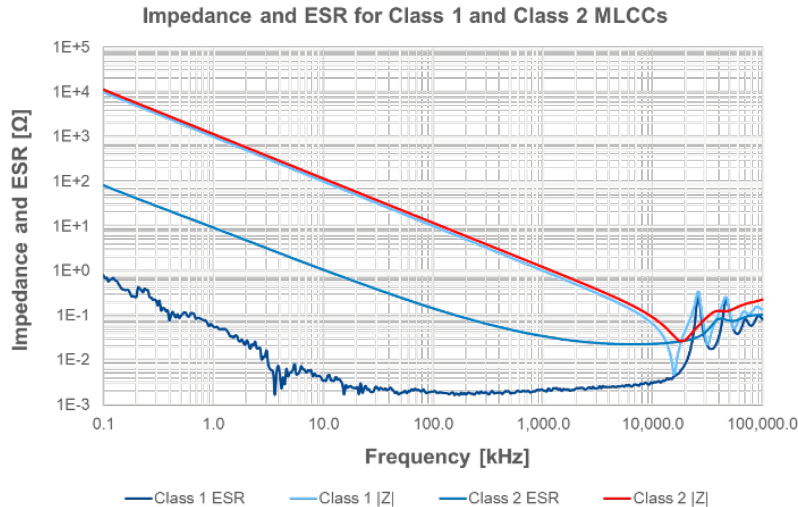
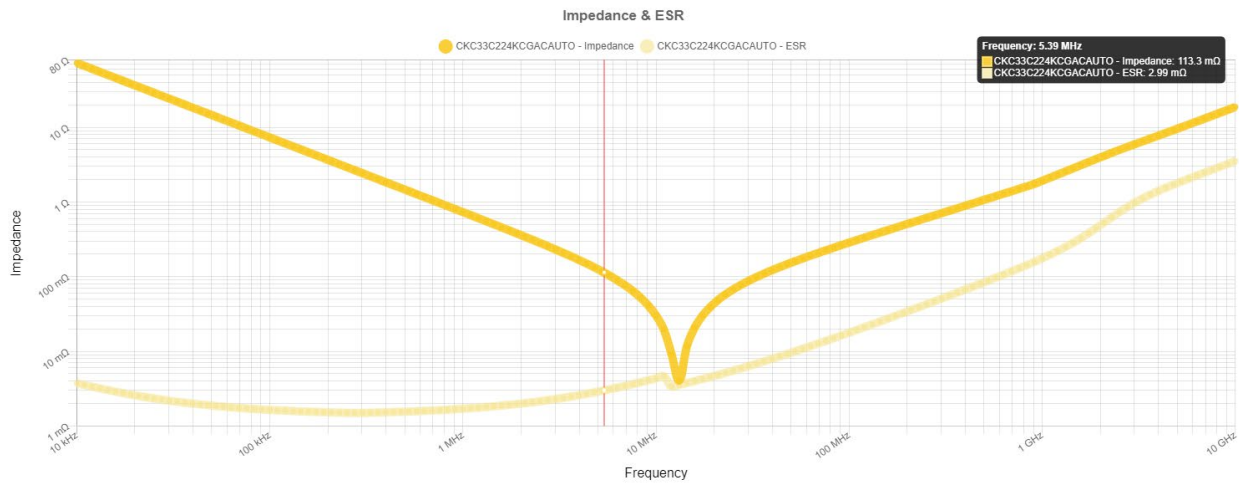

Figure 2 – Impedance and ESR vs frequency for Class 1 and Class 2 MLCCs

YAGEO Group’s Y-SIM tool provides many electrical characteristics for MLCCs including ESR.  
<https://ksim3.kemet.com/>



## What is Dissipation Factor (DF)?

Dissipation Factor (DF) is a measure of a capacitor's losses under AC conditions and is defined as the ratio of ESR (resistive power loss) and reactance (reactive power). Higher DF signifies higher ESR in the capacitor causing self-heating due to  $I^2R$  losses. DF is sometimes referred to as loss tangent since it represents the angle between the resistive and reactive vectors in the complex impedance graph seen below.

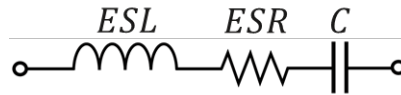

$$X_C = j \frac{1}{\omega C}$$

$$DF = \frac{ESR}{|X_C|}$$

$$\tan \delta = DF$$

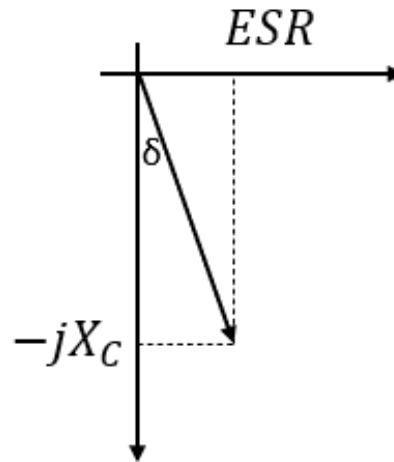

Dielectric	Typical DF Values
Class 1 C0G/U2J	<0.1%
Class 2 X7R/X5R	1% to 10%

DF is measured using an LCR meter under the following conditions:

Capacitance	AC Voltage	Frequency
$C \leq 1000 \text{ pF}$	$1.0 \pm 0.2 \text{ Vrms}$	$1 \text{ MHz} \pm 100 \text{ kHz}$
$C \leq 10 \text{ } \mu\text{F}$	$1.0 \pm 0.2 \text{ Vrms}$	$1 \text{ kHz} \pm 50 \text{ Hz}$
$C > 10 \text{ } \mu\text{F}$	$0.5 \pm 0.1 \text{ Vrms}$	$120 \text{ Hz} \pm 10 \text{ Hz}$

DF for YAGEO Group capacitors can be found on the part number specification sheet.

<https://yageogroup.com/products/Capacitors?79=558>

## What is Equivalent Series Inductance (ESL)?

Equivalent Series Inductance, or ESL represents the inductive reactance of a capacitor and is usually expressed in nanohenries (nH) or picohenries (pH). The simplified RLC model in the figure below shows that ESL is in series with the ESR and capacitance elements which is why it's referred to an Equivalent Series Inductance. All capacitors, regardless of type or form factor will have some parasitic inductance that needs to be considered, especially when using at higher frequencies. Inductance in capacitors is due to material properties and physical geometry. For example, a short and wide capacitor will have lower inductance than a long and narrow capacitor. Capacitors with leads will have much higher capacitance than surface mount (SMD).

Since MLCCs are small, surface mount devices, their inductances are usually very low compared to other capacitor technologies. Typical ESL values for MLCCs are less than 1nH and even as low as 0.2nH for very small EIA case sizes.



$$Z = \sqrt{ESR^2 + (X_L - X_C)^2}$$

$$X_L = j\omega ESL$$

$$X_C = j \frac{1}{\omega C}$$

Case Size	Typical ESL Range
0402	200pH - 400pH
0603	300pH - 500pH
0805	350pH - 600pH
1206	400pH - 650pH
1210	400pH - 650pH
1812	500pH - 750pH
1825	500pH - 750pH
2220	600pH - 850pH
2225	600pH - 850pH

Typical ESL values for MLCCs

## What is Series Resonant Frequency (SRF)?

Series Resonant Frequency (SRF) is the frequency where the capacitive and inductive reactances are equal in magnitude but cancel each other out leaving only ESR remaining in the impedance equation. The magnitude of the impedance for frequencies below the SRF are dominated by the capacitive reactance. Frequencies above SRF are dominated by the inductive reactance. As seen in the SRF equation below, increasing either ESL or Capacitance will result in a lower SRF.



$$Z = \sqrt{ESR^2 + (X_L - X_C)^2}$$

$$X_L = j\omega ESL$$

$$X_C = j\frac{1}{\omega C}$$

$$SRF \rightarrow X_L + X_C = 0$$

$$SRF = \frac{1}{\omega * ESL * C}$$

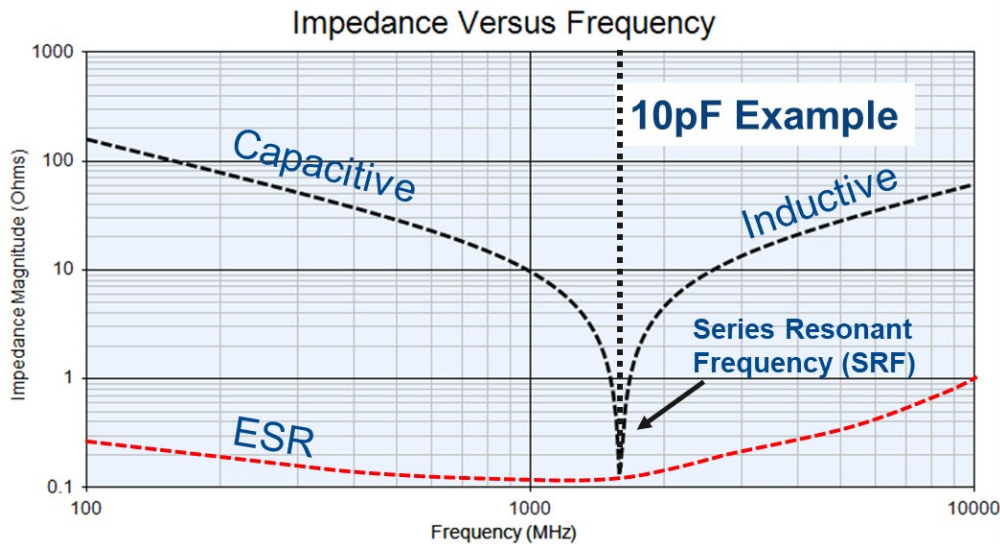

Impedance and ESR vs Frequency for 10pF MLCC

## Why does capacitance change with DC voltage?

When purchasing a class II Multilayer Ceramic Capacitor (MLCC) from any manufacturer, the nominal capacitance is specified in the datasheet using specific measurement parameters such as frequency, AC voltage, and DC voltage. When measuring the capacitance per the manufacture’s recommendations, the capacitance should read within the tolerance of the part number that was purchased. However, under applied DC voltages, there will be a noticeable decrease in capacitance in some cases up to 90% at rated voltage. (See Figure Below)

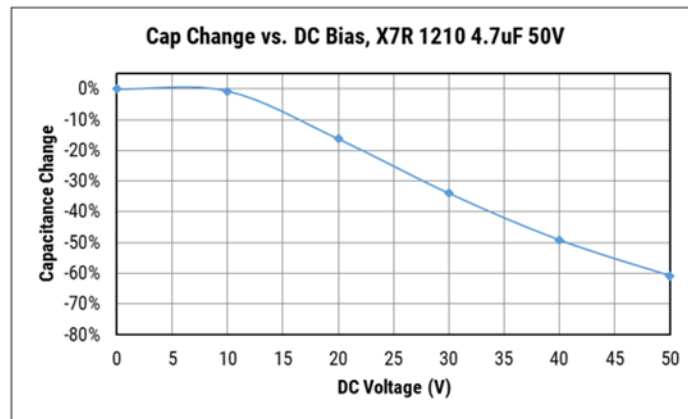

VCC is a phenomenon in Class II and Class III MLCCs where the capacitance will decrease under applied DC voltages. This effect is most noticeable when operating at voltages close to the rated voltage and where high capacitance is a critical parameter in the design. VCC occurs in all Class II and Class III -X7R, X5R, Y5V, Z5U, etc.- capacitors from any manufacturer and is related to the design and material properties of the MLCC.

### What Causes VCC?

MLCCs are constructed using alternating layers of ceramic dielectric and metal electrodes. Figure 1 shows the calculation of capacitance for an MLCC where the A is the active area of the electrodes, K is the relative dielectric permittivity, N is the number of electrodes and d is the dielectric thickness. By increasing either A, K, or N, the net result will be an increase in capacitance

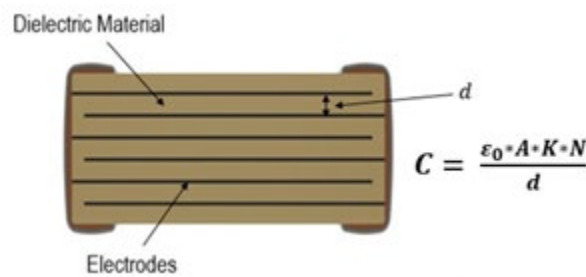

Class II MLCCs are made from a (BaTiO<sub>3</sub>) ferroelectric material which has a crystalline structure containing Barium, Titanian, and Oxygen atoms. Above its curie point (~130°C) BaTiO<sub>3</sub> has a cubic crystal structure but as it cools down below its curie point, it transitions into a tetragonal shape. See Figure 3. The effect is an immediate spontaneous polarization of the material, forming dipoles which arrange into domain regions. The creation of the dipole is due to the shift of the titanium ion within the crystal lattice structure causing an electric field to exist. The arrangement of the domain regions within the dielectric are randomly scattered throughout the material in which there is no net electric polarization of the material. The electric fields of each of the dipoles cancel each other out into a neutral state. The result of the spontaneous polarization of

the material is a high permittivity which gives Class II and III MLCCs their high capacitance. During a capacitance measurement using small AC voltages, the titanium ion is free to move with the alternating electric field.

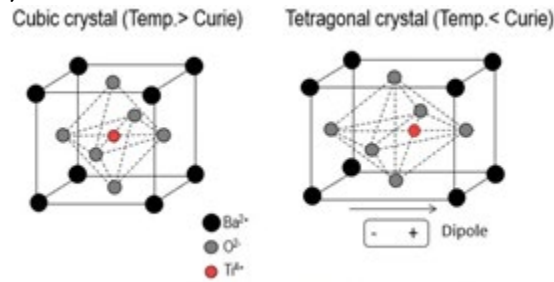

When DC voltage is applied to the MLCC, an electric field would be present throughout the dielectric and the titanium ion would now be influenced by both the DC electric field and AC electric field. As the DC voltage increases, the titanium ion becomes “locked” into place preventing it from being influenced by the AC voltage thus reducing the dielectric constant of the material. This results in a measurable drop in capacitance in the MLCCs

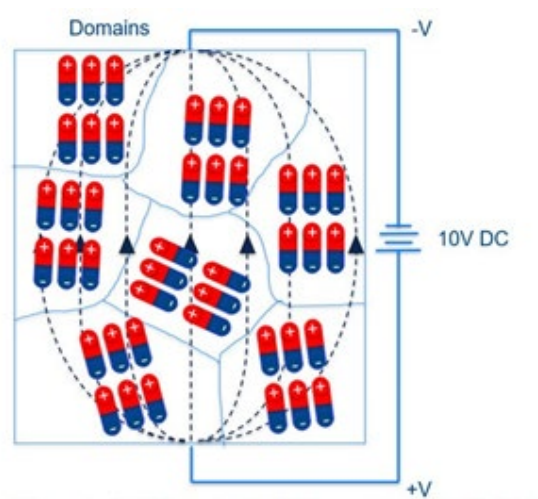

## Factors Influencing VCC

Not all Class II and Class III MLCCs will have the same level of capacitance loss versus DC voltage. Some MLCCs may lose 10% capacitance at rated voltage while another MLCC of the same case size may lose 70% at rated voltage. There are two factors that influence VCC:

1. Applied Voltage – As voltage increases on an MLCC, higher electric fields are present on each active layer. Therefore, as voltage increases, capacitance loss also increases.
2. Dielectric Material – Class II and III MLCCs are made from Ba- TiO<sub>3</sub> material but also include other materials such as dopants to improve performance, quality, and processing. Formulation differences between MLCCs can have a significant impact on VCC.
3. Design – MLCCs are constructed using alternating layers of ceramic dielectric and metal electrodes (Figure X). The dielectric thickness (separation between the electrodes) can range from 10µm down to below 1µm. As the dielectric thickness decreases, the electric field on each of the MLCC layers increases thus increasing the effect of VCC.

## What about Class I MLCCs?

Class I MLCCs are made from CaZrO<sub>3</sub> dielectric which is a paraelectric material. Therefore, Class I MLCCs are considered to be very stable and have almost not capacitance shift with DC or AC voltage.

## Where to find VCC for your MLCC?

YAGEO Group's Y-SIM tool provides designers with electrical characteristics such as Impedance, ESR, VCC, VCAC, TCC, S-Parameters, and Ripple Current. Go to <https://ksim3.kemet.com/>

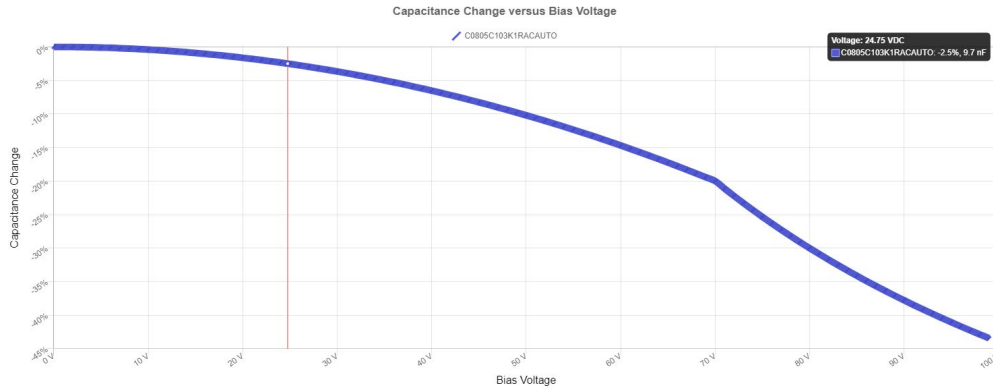

In addition to YAGEO Group's Y-SIM tool, detailed specification sheets also provide electrical characteristics. <https://yageogroup.com/products/Capacitors?79=558>

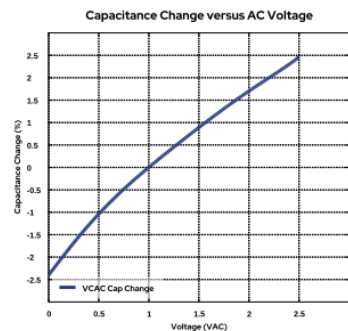
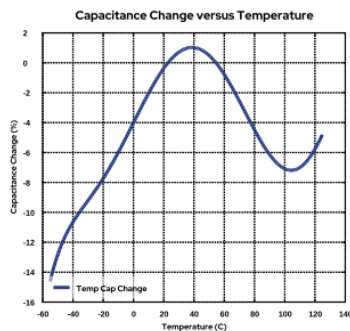
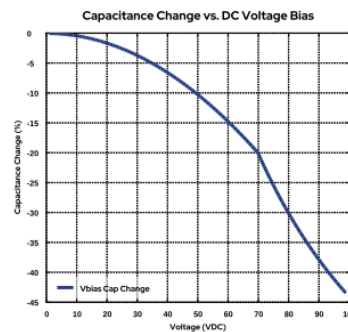
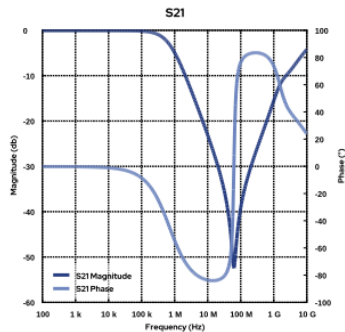

## Why does capacitance appear to be out of tolerance when I measure it?

### Overview

There are many instruments that can be used to measure the electrical properties of capacitors. When measuring capacitance, these instruments apply a known AC voltage and frequency across the capacitor (device-under-test [DUT]) to measure the corresponding impedance. The capacitance is then extracted from the impedance measurement. The table below illustrates the voltage and frequency parameters recommended for measurement of Class-II and Class-III ceramic capacitors.

Capacitance	Voltage	Frequency
≤ 1,000 pF	1.0 Vrms	1 MHz
> 1,000 pF	1.0 Vrms	1 kHz
>10 uF	0.5 Vrms	120 Hz

Table 1 – Measurement voltage and frequency by capacitance value

### Output Impedance of the Instrument

All capacitance measurement equipment will have a known output impedance greater than zero. The output impedance will vary based upon the model and/or capacitance measurement range of the equipment. Impedance is a critical factor in the measurement of capacitance, especially when the impedance of the device under test (DUT) approaches the impedance of the instrument. The figure shows the general schematic of a capacitance measurement with the instrument source impedance.

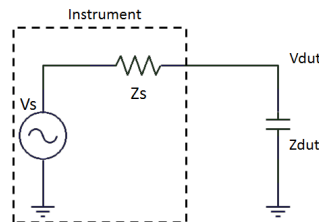

When a DUT is being measured for capacitance, the source voltage of the test equipment must be set to the desired measurement voltage. In the case of a 10uF capacitor, the source voltage would be 1.0 Vrms based on the table above. If the instrument's output impedance is high enough, it will cause a voltage divider and reduce the actual test voltage across the DUT. The equation below shows the voltage across the DUT during the measurement. From the equation, we can see that as the source impedance ( $Z_s$ ) approaches the impedance of the DUT, there will be a voltage drop across the part. Using this equation, we can plot the percent voltage drop across the DUT during measurement as a function of capacitance as shown in the voltage versus capacitance graph. The graph below illustrates a drop in voltage at around 100nF with only 15% of the voltage at 10uF. The voltage steps up to around 80% just after 10uF due to the change in frequency.

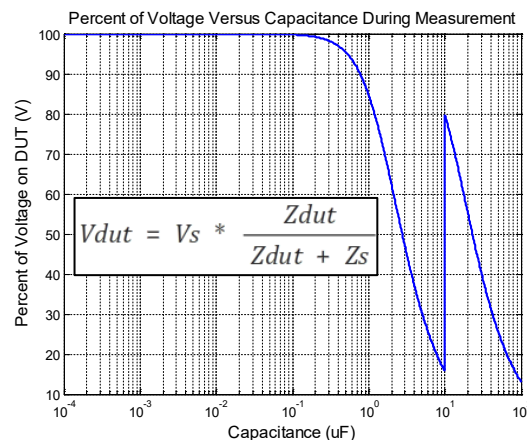

From Table 1, the desired voltage and frequency are 1.0 Vrms and 1 kHz, respectively. In this example, the output impedance of the test meter is 100Ohms based on the meter’s specifications. At 1 kHz, the DUT impedance will be 15.91Ohms. Using the voltage divider equation, the voltage across the DUT will be approximately 157 mV. Thus, only about 15% of the output voltage is actually applied to the DUT. Because of the resulting voltage drop across the DUT, the capacitance measurement is invalid since it does not meet the test specifications outlined in Table 1. It is important to maintain a constant test voltage while measuring capacitance. Figure 3 shows an actual measurement of a 10uF capacitor using the Agilent E4980 LCR meter. The measured AC voltage across the capacitor is only 186 mV, far below the 1 Vrms specification. The result of the test falsely indicates that the capacitor does not meet its rated specification. The next section will show how to correct for this anomaly and limitation.

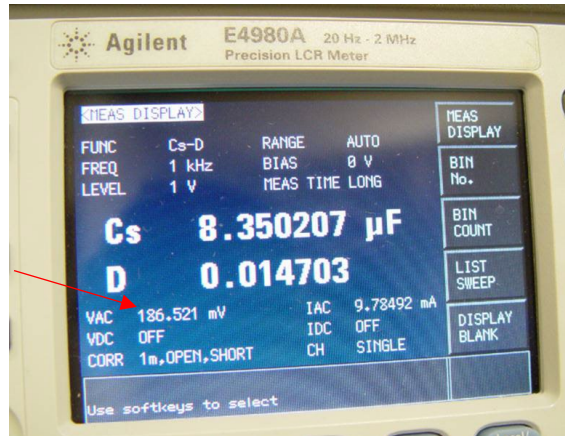

Capacitance measurement of 10uF capacitor with ALC off

### How do we correct for the voltage drop?

In order to ensure the voltage across the DUT is maintained at the desired level, the output voltage needs to be increased on the test meter to adjust for the voltage divider. Some capacitance measurement equipment will have a function called Auto-Level Control (ALC) which does this automatically. This feature enables the instrument to automatically increase the source voltage to meet the set voltage. When considering the case in Example 1 above, without the ALC function, the voltage across the DUT was 186 mV with a set voltage of 1.0 Vrms. If we enable the ALC function, the instrument will automatically raise the source voltage to achieve the desired 1.0 Vrms across the DUT. Figure 4 shows a measurement of the same 10uF capacitor using the Agilent E4980 LCR meter with the ALC feature set to ON. The result of the test shows the capacitor measures within the 10% tolerance range.

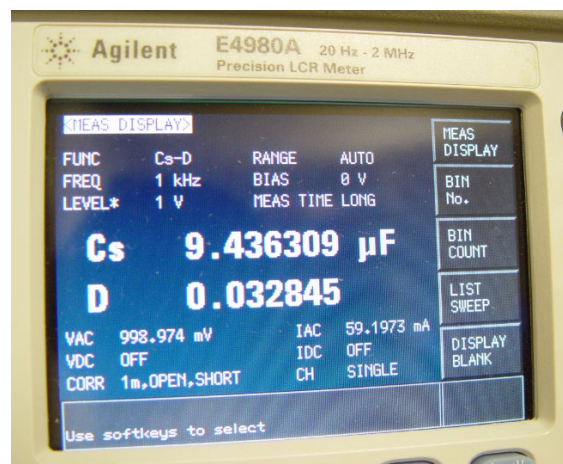

Capacitance measurement of 10uF capacitor using ALC function

## Is the ALC function the only way to avoid this issue?

No, there are other methods to avoid a voltage drop during the capacitance measurements. Per the voltage divider equation above, as the source impedance decreases, so does the voltage drop. To solve this, impedance measurement equipment suppliers such as Keysight Technologies provide LCR meters with much lower source impedances such as the E4981A Capacitance Meter. Due to the very low source impedance, the ALC function is not necessary.



Output impedance	Frequency: 120 Hz	SLC OFF ( $\geq 220 \mu\text{F}$ range)	1.5 $\Omega$ (nom.) <sup>1</sup>
		SLC ON ( $\geq 220 \mu\text{F}$ range)	0.3 $\Omega$ (nom.) <sup>1</sup>
		2.2 $\mu\text{F}$ to 100 $\mu\text{F}$ range	0.3 $\Omega$ (nom.) <sup>1</sup>
		10 nF to 1 $\mu\text{F}$ range	20 $\Omega$ (nom.) <sup>1</sup>
Output impedance	Frequency: 1 kHz	SLC OFF ( $\geq 22 \mu\text{F}$ range)	1.5 $\Omega$ (nom.) <sup>1</sup>
		SLC ON ( $\geq 22 \mu\text{F}$ range)	0.5 $\Omega$ (nom.) <sup>1</sup>
		220 nF to 10 $\mu\text{F}$ range	0.3 $\Omega$ (nom.) <sup>1</sup>
		100 pF to 100 nF range	20 $\Omega$ (nom.) <sup>1</sup>
	Frequency: 1 MHz / 1 MHz $\pm$ 2% / 1 MHz $\pm$ 1%		20 $\Omega$ (nom.) <sup>1</sup>

## Aspects of Class-II and Class-III Dielectrics

The measured capacitance of Class-II (X7R, X5R, X8R, etc.) and Class-III (Y5V, Z5U, etc.) devices will change the applied voltage is increased and decreased. The relative permittivity of these dielectric materials are affected by both AC and DC voltage. The severity of the change depends on the magnitude of the voltage, the dielectric type, and the thickness of the dielectric<sup>1</sup>. Figure 5 illustrates typical capacitance change versus AC voltage of a Class-II capacitor. Figure 6 illustrates typical capacitance change versus DC voltage on a 16VDC rated part. Based on the plots in Figures 5 and 6, it is important to note that both AC and DC applied voltages must be considered when making a capacitance measurement.

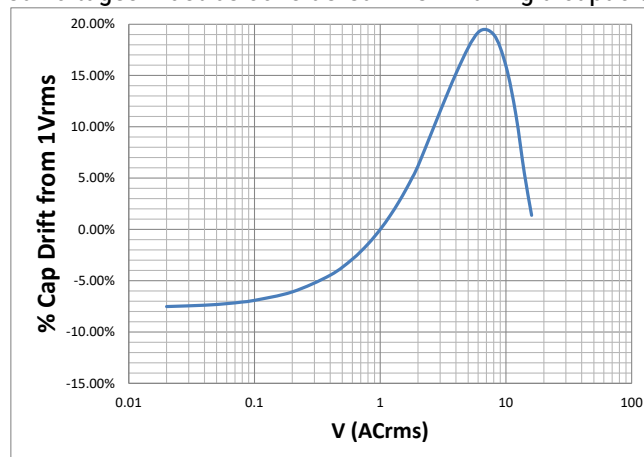

Capacitance versus AC Voltage

## What are the main differences between BME and PME?

Key Words: BME, PME, Electrode

Multilayer Ceramic Capacitors (MLCCs) are constructed using alternating layers of ceramic dielectric and metal electrodes as seen in the image below.

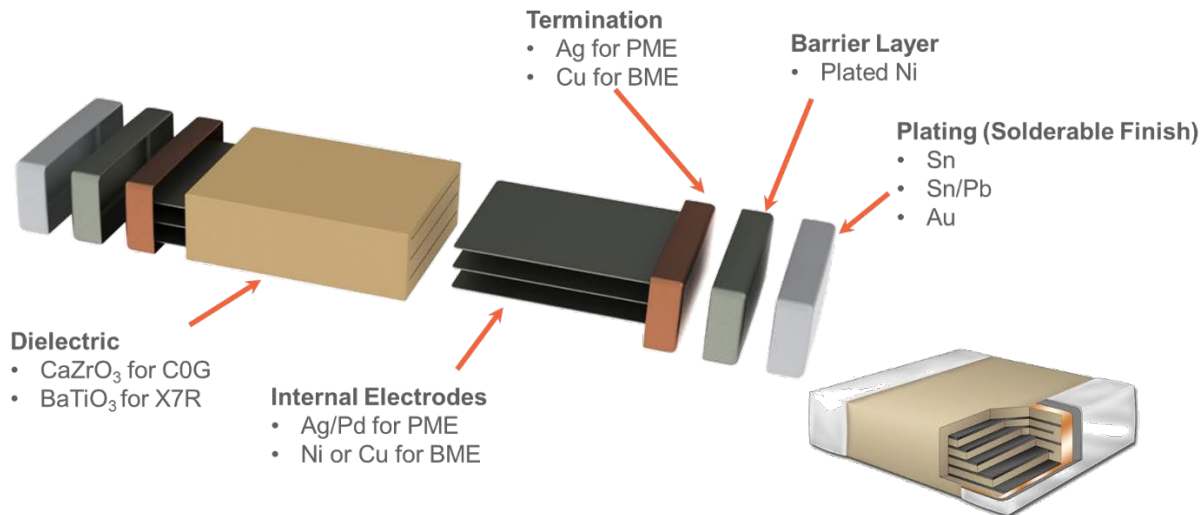

MLCCs internal electrodes can be constructed using either PME (precious metal electrode) or BME (base metal electrode) systems. KEMET PME technology uses combinations of Palladium and Silver (AgPd) as the inner electrodes. Historically, MLCCs were made from PME materials in which the electrodes were made from silver palladium. Over time, as dielectrics became thinner and cost needed to be reduced, suppliers switched to BME materials in which the electrodes are made from either nickel or copper (Ni or Cu). Today, the vast majority of MLCCs are constructed using nickel-based BME technology. PME based MLCCs are still widely used for example in MLCCs for defense and aerospace applications such as MIL-PRF-55681 and MIL-PRF-123. However, with the introduction of MIL-PRF-32535 in 2017, KEMET also offers high reliability MLCCs utilizing BME technology.

## Mounting and Handling

### What is KEMET's recommended solder reflow profile?

All KEMET SMD multilayer ceramic capacitors (MLCCs) are compatible with convection and IR reflow processes. Each MLCC product datasheet features a solder reflow profile for all termination finishes available for that series. Adherence to these general profiles is important to prevent thermal cracking of the MLCC body, insufficient wetting, and unreliable solder joints.

Profile Feature	Termination Finish	
	SnPb	100% Matte Sn
<b>Preheat/Soak</b>		
Temperature Minimum ( $T_{Smin}$ )	100°C	150°C
Temperature Maximum ( $T_{Smax}$ )	150°C	200°C
Time ( $t_s$ ) from $T_{Smin}$ to $T_{Smax}$	60 - 120 seconds	60 - 120 seconds
Ramp-Up Rate ( $T_L$ to $T_p$ )	3°C/second maximum	3°C/second maximum
Liquidous Temperature ( $T_L$ )	183°C	217°C
Time Above Liquidous ( $t_L$ )	60 - 150 seconds	60 - 150 seconds
Peak Temperature ( $T_p$ )	235°C	260°C
Time Within 5°C of Maximum Peak Temperature ( $t_p$ )	20 seconds maximum	30 seconds maximum
Ramp-Down Rate ( $T_p$ to $T_L$ )	6°C/second maximum	6°C/second maximum
Time 25°C to Peak Temperature	6 minutes maximum	8 minutes maximum

Note 1: All temperatures refer to the center of the package, measured on the capacitor body surface that is facing up during assembly reflow.

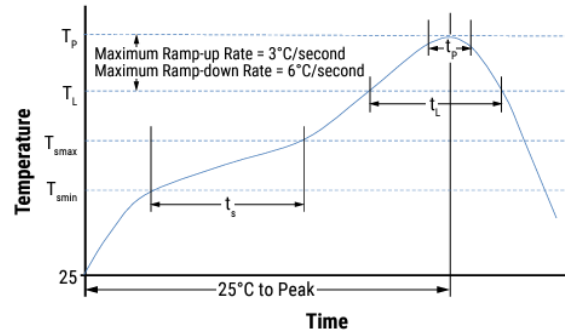

## What is YAGEO's recommended solder reflow profile?

All YAGEO SMD multilayer ceramic capacitors (MLCCs) are compatible with convection and IR reflow processes. Each MLCC product datasheet features a solder reflow profile for all termination finishes available for that series. Adherence to these general profiles is important to prevent thermal cracking of the MLCC body, insufficient wetting, and unreliable solder joints.

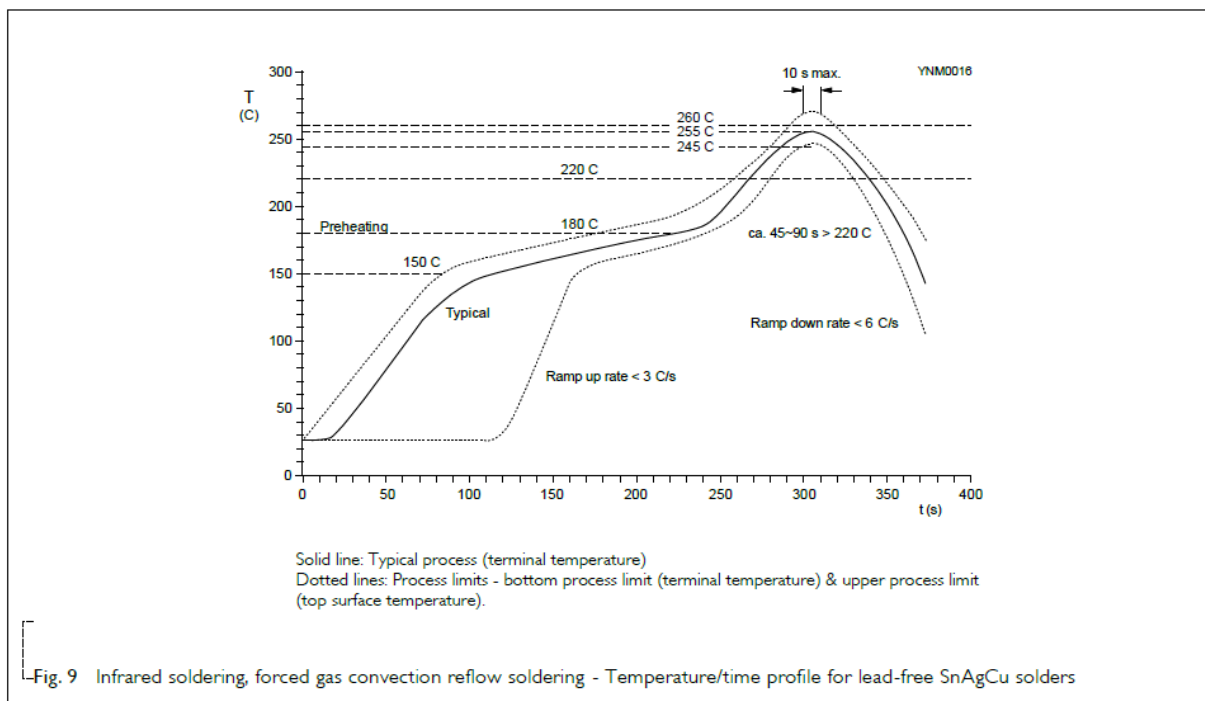

## Is it OK to hand solder MLCCs using a soldering iron?

Since MLCCs utilize a ceramic dielectric material, they are prone to cracks due to excessive temperature gradients. Therefore, care must be taken when employing hand soldering techniques to prevent temperature gradients. Below are some guidelines to help mitigate the risk of thermal cracks during the hand soldering process. This process is not recommended for case sizes larger than EIA 1210.

### **Guideline 1: With Pre-Heating**

1. Utilize 1.0mm thread eutectic solder with soldering flux in the core. Either a rosin-based or nonactivated flux is recommended.
2. The capacitors shall be pre-heated so that the temperature gradient between the devices and the tip of the soldering iron is  $\Delta T \leq 120^\circ\text{C}$  or below.
3. The temperature of the solder iron tip should not exceed  $300^\circ\text{C}$ .
4. The required amount of solder shall be melted in advance on the soldering tip.
5. After soldering the capacitors shall be cooled gradually at room ambient temperature. Forced air cooling is not permitted.

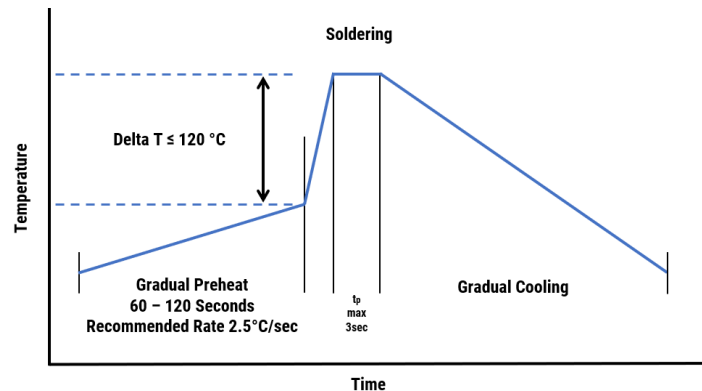

### **Guideline 2: Without Pre-Heating**

1. Soldering iron tip shall never directly touch the ceramic dielectrics and terminal electrodes of the capacitors.
2. Lands are sufficiently pre-heated with a soldering iron tip before sliding the soldering iron tip to the terminal electrode of the capacitor for soldering.

## What is the recommended cleaning procedure for MLCCs after mounting?

To clean MLCCs after assembly process:

YAGEO Group recommends solvents like isopropyl alcohol (IPA), ethanol, deionized water and other standard PCB cleaning solutions such as Oakite, Okemclean, Biokleen, PINE ALPHA cleaners (Arakawa), Clean through series cleaners (Kao), etc. Aggressive solvents are not recommended.

MLCCs should be cleaned thoroughly with no remnants of flux residue.

Insufficient washing might leave traces of flux residue causing degradation of electrical properties of the capacitor such as its insulation resistance.

If using Ultrasonic cleaning, YAGEO Group recommends the guidelines below:

- Ultrasonic Power: 20 W/ℓ maximum
- Ultrasonic Frequency: 20 kHz - 40 kHz
- Ultrasonic Temperature: 60°C / 140°F maximum
- Ultrasonic Cleaning Duration: 5 minutes maximum

While using Ultrasonic cleaning, it is important to consider that excessive vibration of PCBs or resonance between mounted components and the PCB may cause cracking in the solder joints or capacitors. YAGEO Group recommends testing your cleaning process on final production PCB to validate that it is suitable for the capacitors and PCBs used.

## Can MLCCs be reworked after mounting?

Since MLCCs utilize a ceramic dielectric material, they are prone to cracks due to excessive temperature gradients. Therefore, care must be taken when employing any rework procedures to prevent temperature gradients. Below are some guidelines to help mitigate the risk of thermal cracks during any rework process. This process is not recommended for case sizes larger than EIA 1210.

### Risks Involved

- Cracking – MLCCs are brittle and can crack during the removal and resoldering process.
- Thermal Shock – Excessive or uneven heating of the MLCC can damage the ceramic layers, causing future component failure.
- Pad Damage – PCB pads can lift or delaminate if not handled properly.

Below is a guideline to help mitigate the risks involved when reworking an MLCC.

1. Gradually preheat the PCB so that the temperature gradient between the devices and the tip of the soldering iron is  $\Delta T \leq 120^\circ$  or below
2. Using a Hot Air Rework station, apply controlled heat evenly to warm the component and the surrounding area
3. Using fine-tipped tweezers that are ESD safe, gently remove the component from the board. NOTE: Do not twist or pry the component off the board.
4. Clean the pad – Use a solder wick and flux to clean off residual solder, then clean the area with isopropyl alcohol
5. Inspect the pads for any lifts, damage, or residual solder
6. Follow the placement guide found under “Is it OK to hand solder MLCCs using a soldering iron” in this FAQ sheet.

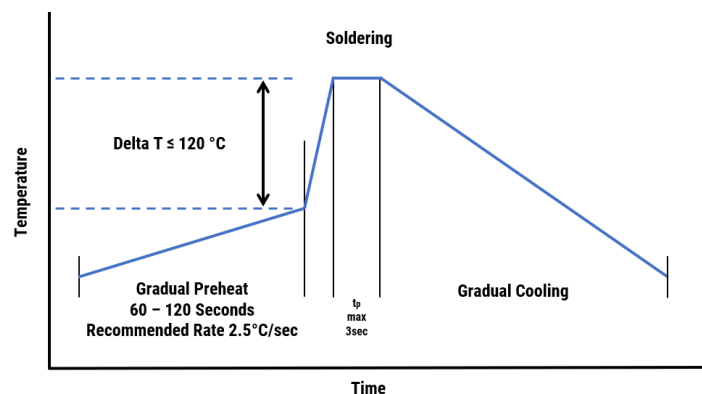

## Do Ceramic Capacitors have an MSL Rating?

The Moisture Sensitivity Level (MSL) indicates how long an electrical component can be exposed to ambient humidity before it becomes compromised for the reflow soldering process. Some components are sensitive to humidity and require moisture sensitive packaging for short- and long-term storage. During the reflow process, the entrapped moisture will turn into gas, violently expanding, and damaging the component. Since not all electronic components will absorb moisture at the same rate, the Moisture Sensitive Level defines the risk for the component and the time the component can be at ambient room conditions prior to reflow. If the time at ambient conditions is exceeded, the components must go through a baking (drying) cycle. Most manufacturers classify components to an IPC/JEDEC Joint Industry Standard (J-STD-033) and per the below table.

MSL Level	Time at Ambient Conditions
1	Unlimited time
2	1 Year
2a	4 weeks
3	168 Hours
4	72 Hours
5	48 Hours
5a	24 Hours
6	0 Hours – Components must go through baking cycle

Moisture Sensitivity Levels per JEDEC

**MLCCs are not sensitive to ambient humidity and have an MSL rating of 1. Therefore, baking is not necessary.**

Note: MSL rating is not related to storage life. The storage life of MLCCs is due to oxidation of the terminations only which affects solderability and is typically within 1.5 years of receipt. Please see YAGEO Group datasheet for actual storage life specification.

## How Long can MLCCs be stored once soldered to a PCB?

YAGEO Group provides guidelines for storing MLCCs on each datasheet. This is usually in the range of 6-18 months depending on the product. However, the storage requirement is only for MLCCs prior to soldering to a PCB. The storage requirements for MLCCs are due to oxidation of the external tin (Sn) termination finish that may reduce solderability. Staying within the YAGEO Group guidelines for storage will ensure optimum solderability. However, once the MLCC is soldered to the PCB, there is no concern with the oxidation and therefore the mounted MLCCs can be stored indefinitely.

## What is the recommended solder fillet height for a KONNEKT Stack in the standard orientation?

Key Words: KONNEKT, Solder Fillet, Solder Volume, Standard Orientation

When mounting a KONNEKT capacitor in standard orientation, KEMET recommends using the typical solder volume for a single chip of equivalent case size while not exceeding a fillet height (Y). It is crucial to maintain a solder fillet height (X) that does not contact the TLPS joint (Y). This ensures that the solder contacts and wicks only to the bottom chip in the assembly and that the TLPS joint remains unaffected, thereby guaranteeing a reliable mechanical and electrical connection to the PCB or substrate.

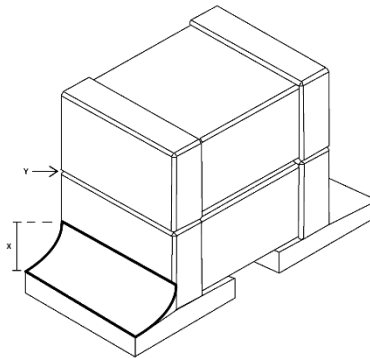

## What is the recommended solder fillet height for a KONNEKT Stack in a Low-Loss orientation?

Key Words: KONNEKT, Solder Fillet, Solder Volume, Low-Loss

When mounting in low-loss orientation, KEMET recommends a solder fillet height (X) no greater than 1mm and no less than 0.5mm. This ensures the solder contacts and wicks to all the chips in the KONNEKT stack, and ensures all chips are mechanically and electrically connected to the PCB.

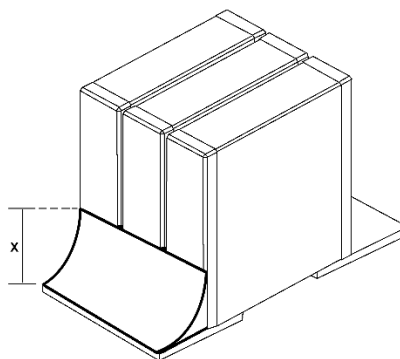

## What is the recommended solder fillet height of an MLCC?

Key Words: Solder Fillet, Solder Volume

When mounting MLCCs, YAGEO Group recommends using the solder volume required to create a solder fillet no greater than  $\frac{3}{4}$  of the chip thickness, with a minimum of  $\frac{1}{2}$  the chip thickness. It is crucial to maintain a solder fillet height (X) that does not exceed the height of the chip to minimize the thermal and mechanical stress on the ceramic body. This ensures that the solder contacts and wicks only to the terminations of the chip, thereby guaranteeing a reliable mechanical and electrical connection to the PCB or substrate.

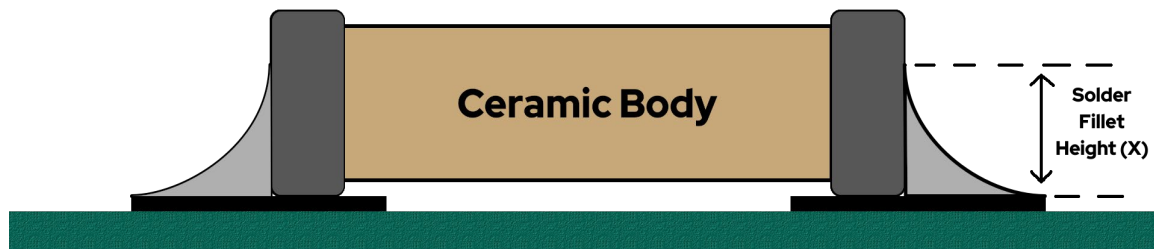

## **Flex Mitigation**

### How do I reduce the chances of failures due to flex cracks?

#### **Reduce Board Flex**

Ceramic materials are inherently brittle and may crack under excessive strain. Therefore, it's important during the manufacturing process not to apply excessive bending on the PCB which can induce flex cracks. One key area of the manufacturing process that can induce excessive board flex is PCB depanelization/singulation. YAGEO Group recommends applying a strain gauge analysis during process development.

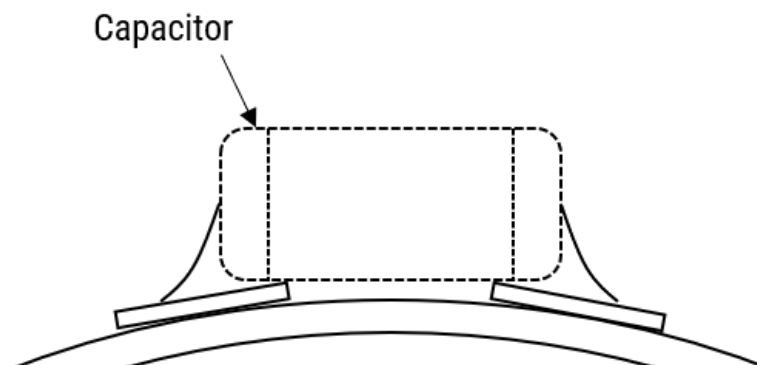

#### **Beware of high-risk areas of the PCB**

- Connectors – MLCCs placed close to connectors are at risk of flex cracks. When connectors are attached to the PCB, excessive force may be applied inducing flex stress on the MLCCs.

- Close to edge of PCB or near scribe lines for depanelization – During depanelization, MLCCs close to the edge may see more flex compared to areas further away. Consider mounting MLCCs parallel to the edge of the PCB to reduce the risk of flex cracks.

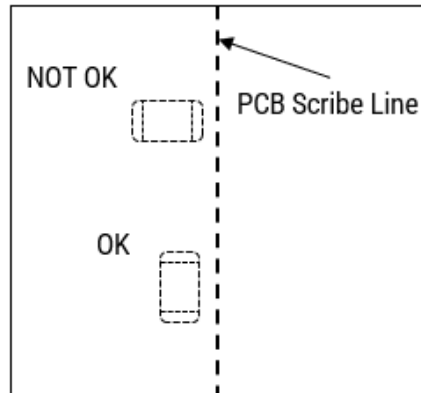

## How does Flexible Termination reduce the risk of flex cracks?

When MLCCs are mounted to PCBs, excessive board strain can lead to excessive stress on the MLCC leading to flex cracks and short circuits. Therefore, to alleviate this stress, YAGEO Group offers a flexible/soft termination options that can drastically improve flex robustness.

YAGEO Group's Flexible Termination/Soft Termination is a layer of highly conductive silver epoxy between the copper termination and the nickel barrier layer. This silver epoxy layer helps mitigate the risk of flex cracks by the following two methods:

- The silver epoxy layer acts as a soft and compliant material between the copper and nickel layer that will absorb the mechanical board strain limiting the stress on the MLCC.
- Under extreme board strain, the silver epoxy may tear from the copper termination acting as a mechanical fuse. Although this may result in decreased performance from the MLCC, it will reduce the likelihood of a short circuit.

YAGEO Group's flexible/soft termination MLCCs provide up to 5mm capability from EIA 0603 – 1210 case sizes and 3mm capability for larger case sizes.

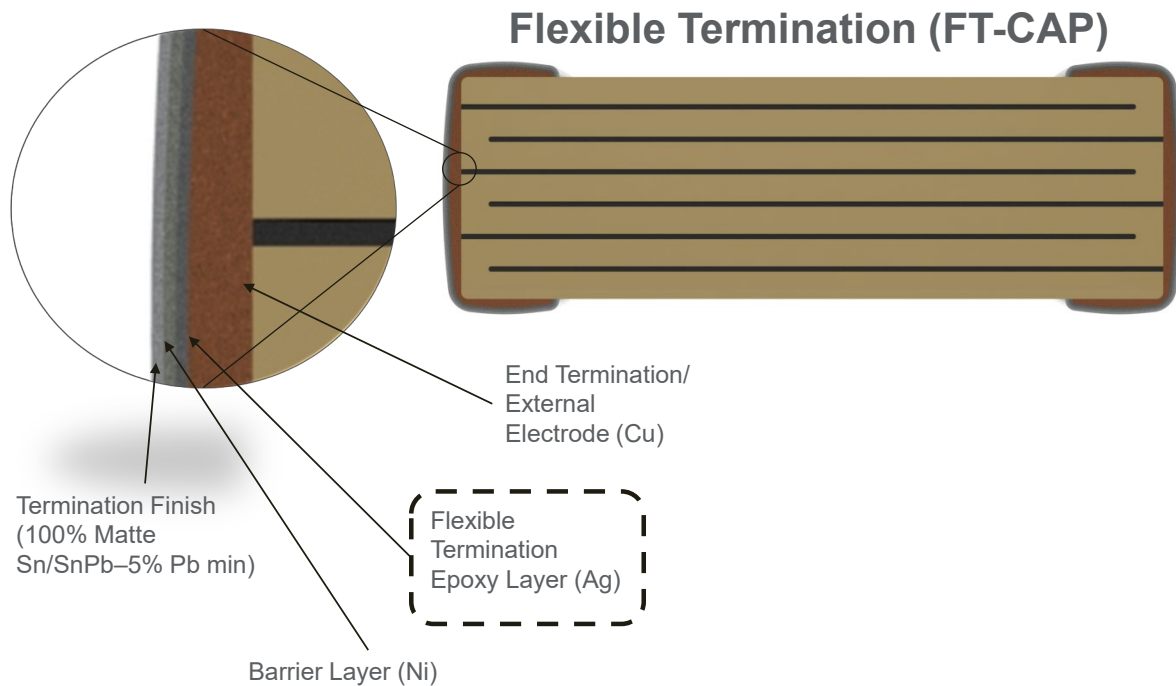

### Does a Flex Crack always have the same crack signature?

Yes; There is a distinctive crack signature for board flex cracks – it always starts near the edge of the termination margin, and usually extends upwards toward the termination face. The flex crack signature is distinctly different than other crack signatures in MLCC's.

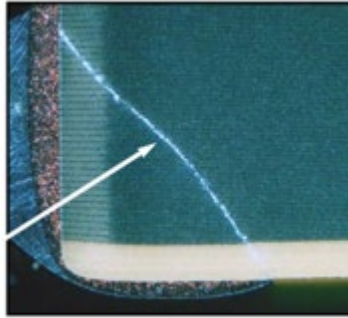

Typical Flex Crack

### Do flex cracks always result in immediate short circuits?

No; as with all cracks in MLCC's, there needs to be some type of ionic penetration or humidity along the crack path which allows current to flow between electrode plates of opposite polarity for the chip to fail.

### Does YAGEO Group ever ship capacitors with flex cracks, while still in the tape & reel?

No; Since MLCCs require excessive strain to induce a flex crack, this can only occur after the mounting process.

## High Voltage

### What is ArcShield™ Technology?

ArcShield™ is a patented technology that utilizes a unique internal shield electrode structure that is designed to suppress an arc-over event while increasing the available capacitance. Developed on the principle of a partial Faraday cage, this internal system offers unrivaled performance and reliability when compared to external surface coating technologies.

#### Benefits of ArcShield Technology

- Higher capacitance available compared to standard designs.
- Minimizing arcing potential at higher voltages.
- Increases breakdown voltage providing higher reliability.

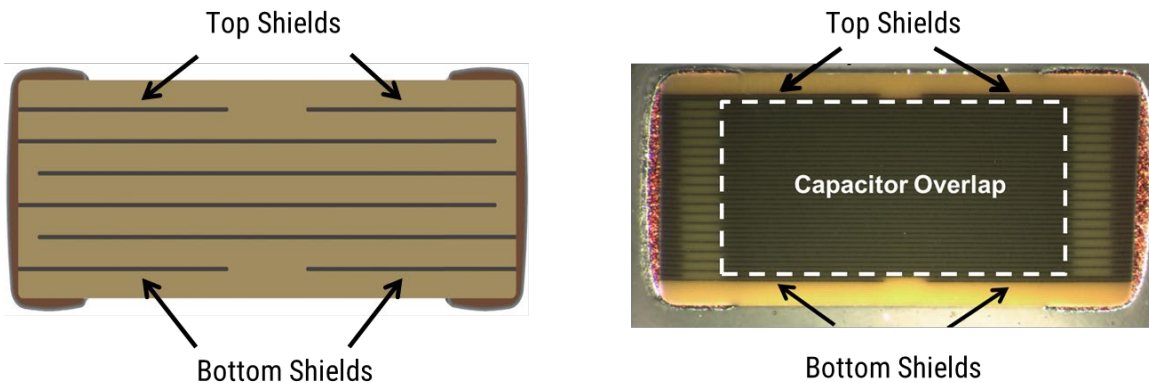

### What is the difference between Creepage vs Clearance?

Creepage Distance: Shortest distance between two conductors and along an insulated surface.

Clearance Distance: Shorted distance in the air between two conductors

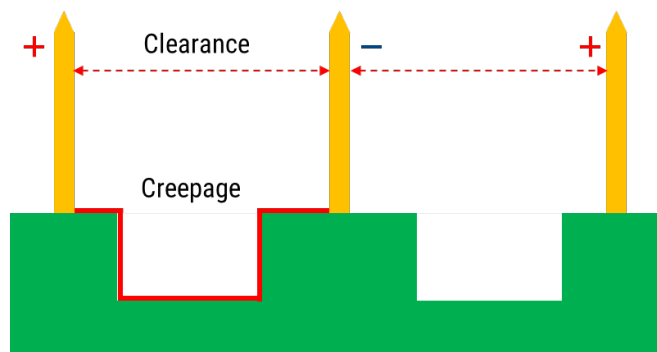

In high voltage designs, it is important to consider the creepage and clearance distances between uninsulated Printed Circuit Board (PCB) conductors, which include lands (pads), terminals, and component terminations. As application voltages increase, the required distance between two conductors must also increase to prevent arcing, which can lead to component damage and catastrophic circuit failure. Minimum required creepage and clearance distances are defined in published industry standards such as IEC 60664. Factors that influence the minimum required distances include voltage, altitude, air quality, and material.

For surface mount multilayer ceramic capacitors (SMD MLCCs), the dimension between the terminations must meet creepage distance requirements. This dimension is identified in KEMET MLCC collateral material as the "Separation Minimum" and is provided in the "Dimensions" table. Please compare this dimension to the minimum creepage distance outlined in IEC 60664 and for your specific application requirement and environment.

Clearance = Creepage

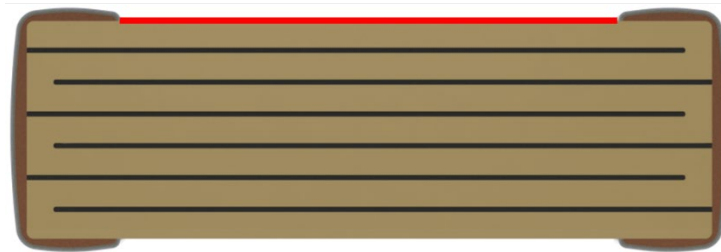

## How do I reduce the risk of arcing in high voltage applications?

### **Coating for High Voltage MLCCs**

For MLCC ratings  $\geq 1500V$ , it is recommended to apply a conformal coating to MLCC to prevent surface arcing. To reduce possibility of inducing cracks in the MLCC, select a coating with thermal expansions close to that of the MLCC.

### **Slits in PCB**

It is recommended to apply a slit in the PCB under the MLCC to improve washing of flux residue.

- Recommended for case sizes  $\geq 1206$
- The width (w) of the slit should be 1mm
- Length of the slit should be as short as possible to prevent damaging the MLCC due to mechanical stress of the PCB.
- Slits also reduce the risk of solder balls under MLCC which decreased the creepage distance.

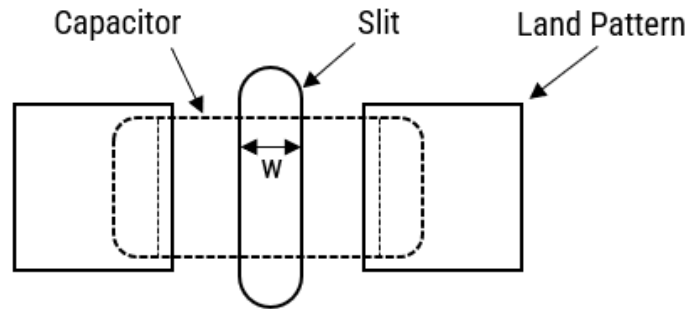

## Solder Balls

Improper reflow techniques and/or improper washing can induce solder balls under or adjacent to the MLCC. Solder balls reduce the creepage distance between the MLCC terminations and increase the risk of arcing or damage to the ceramic material. To reduce the risk of solder balls:

- Follow YAGEO Group's solder recommendations as outlined in the datasheet.
- If performing a cleaning procedure, properly clean the PCB per YAGEO Group's cleaning recommendations.
- Add slit to the PCB as shown above.

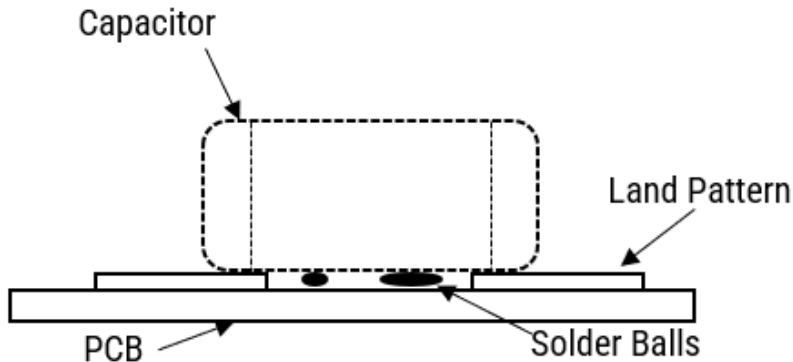

## Electrostatic Discharge (ESD) Rated MLCCs

### What is ESD?

ESD, or Electrostatic Discharge refers to the release of static electricity when two objects come into contact. Electrostatic discharge voltages can be as high as 30kV and produce currents of 30 amps in some cases. However, the total energy of ESD transient pulses is very low (<50mJ) and occurs in less than 100ns. Therefore, ESD is usually harmless to people but can have very negative effects on electronics. If protective measures are not utilized in PCB handling and design, ESD pulses can damage sensitive electronic components impacting overall system reliability.

### How Does YAGEO Group Test MLCCs for ESD Susceptibility?

YAGEO Group tests MLCCs per AEC-Q200, Human Body Model as shown in the discharge network below. During this test, the high voltage power supply charges  $C_d$  through a charge resistor  $R_{ch}$ . Once capacitor  $C_d$  is fully charged, the high voltage relay is closed discharging  $C_d$  into the Capacitor Under test through the discharge resistor  $R_d$ . For ESD testing per AEC-Q200,  $C_d=150\text{pF}$  and  $R_d=2000\text{ Ohms}$ .

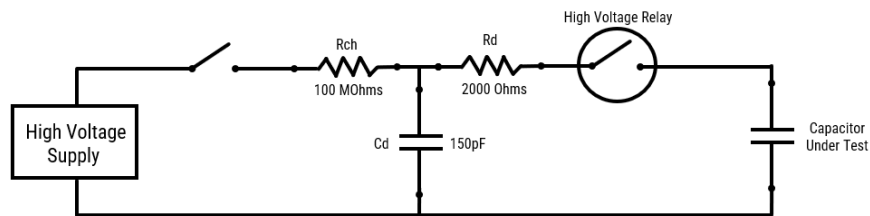

Discharge Network for ESD Testing per AEC-Q200

The typical ESD waveform produced using this network is shown below.

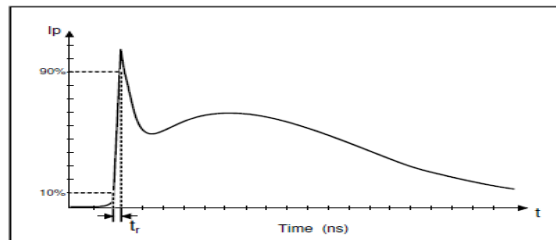

Typical ESD Waveform

Per AEC-Q200, each part type is tested using the below classification tree in order to establish the MLCC's final ESD class.

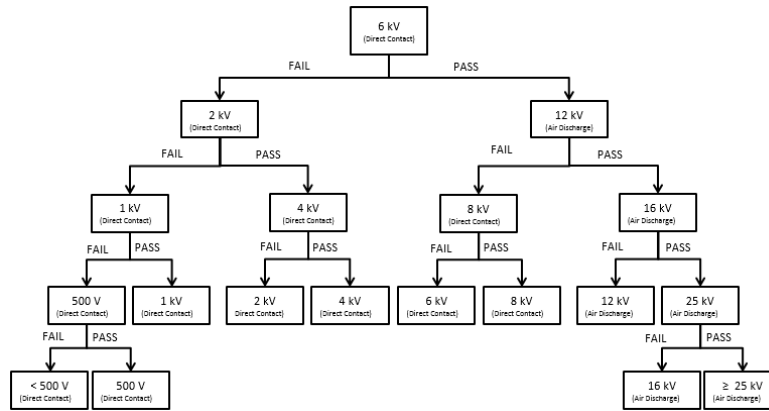

ESD Test Flow per AEC-Q200

Component Classification	Maximum Withstand Voltage
1A	< 500 V (DC)
1B	500 V (DC) a < 1000 V (DC)
1C	1000 V (DC) a < 2000 V (DC)
2	2000 V (DC) a < 4000 V (DC)
3	4000 V (DC) a < 6000 V (DC)
4	6000 V (DC) a < 8000 V (DC)
5A	8000 V (DC) a < 12,000 V (AD)
5B	12,000 V (AD) a < 16,000 V (AD)
5C	16,000 V (AD) a < 25,000 V (AD)
6	≥ 25,000 V (AD)

ESD Classification Table per AEC-Q200  
(DC= Direct Contact Discharge, AD = Air Discharge)

For ESD classification per IEC 61000-4-2, please contact YAGEO Group.

## Does YAGEO Group Offer MLCCs with an ESD Rating?

MLCCs are typically not designed to maximize ESD performance and do not receive in-process testing to maintain a specific ESD rating. Therefore, YAGEO Group's standard Commercial and Automotive Grade products do not have a published ESD rating.

However, YAGEO Group does offer an ESD rated series in both C0G and X7R dielectrics for Commercial and Automotive applications. There are four characteristics that makes YAGEO Group ESD series specifically for ESD applications:

- Designs are optimized to maximize ESD rating.
- Designs are controlled to maintain the ESD rating throughout the product lifecycle.
- Samples from each batch are tested for ESD before shipment.
- ESD rating is provided on the family datasheet and individual specification sheet as seen below.

Capacitance	Cap Code	Case Size/ Series	C0402C			C0603C					
		Rated Voltage (VDC)	16	25	50	16	25	50	63	100	200
		Voltage Code	4	3	5	4	3	5	M	1	2
		Cap Tolerance	ESD Level per AEC-Q200								
1.0 nF	102	J = ±5% K = ±10% M = ±20%	2 kV	2 kV	2 kV	25 kV	25 kV	25 kV	25 kV	25 kV	25 kV
1.5 nF	152		4 kV	4 kV	4 kV	12 kV	12 kV	12 kV	12 kV	12 kV	12 kV
2.2 nF	222		6 kV	6 kV	6 kV	25 kV	25 kV	25 kV	25 kV	25 kV	25 kV
3.3 nF	332		8 kV	8 kV	8 kV	12 kV	12 kV	12 kV	12 kV	12 kV	12 kV
4.7 nF	472		8 kV	8 kV	8 kV	16 kV	16 kV	16 kV	16 kV	16 kV	16 kV
6.8 nF	682		4 kV	4 kV	4 kV	25 kV	25 kV	25 kV	25 kV	25 kV	25 kV
10 nF	103		6 kV	6 kV	6 kV	25 kV	25 kV	25 kV	25 kV	25 kV	25 kV
15 nF	153		6 kV	6 kV	6 kV	16 kV	16 kV	16 kV	16 kV	16 kV	16 kV
22 nF	223		8 kV	8 kV	8 kV	16 kV	16 kV	16 kV	16 kV	16 kV	16 kV
33 nF	333		8 kV	8 kV	8 kV	25 kV	25 kV	25 kV	25 kV	25 kV	25 kV
47 nF	473		12 kV	12 kV		25 kV	25 kV	25 kV	25 kV	25 kV	
68 nF	683		12 kV			25 kV	25 kV	25 kV	25 kV	25 kV	
100 nF	104		16 kV			25 kV	25 kV	25 kV			
150 nF	154					25 kV	25 kV	25 kV			
220 nF	224					25 kV	25 kV	25 kV			

KEMET Datasheet Waterfall Table with ESD Ratings

## Why are MLCCs used for ESD Suppression?

MLCCs are a common choice for ESD suppression due to their small case size, low cost, and effectiveness in protecting sensitive integrated circuits. MLCCs suppress ESD by absorbing the charge from the source of the ESD. To illustrate this concept, below are two images showing a capacitor C1 being discharged into capacitor C2 through a switch. In the picture on the left, capacitor C1 is charged to V1 and establishes a charge Q1. Since ESD sources (such as the human body) have a relatively low capacitance, the resulting charge Q1 will also be low. When the switch is closed, C1 is discharged into C2 (which represents an MLCC used to suppress ESD transients). After the switch is closed, the corresponding charge from C1 now must be shared between C1 and C2. From the equation on the right, as C2 increases, the resulting voltage across C2 will also decrease. Therefore, higher capacitance values of C2 will offer much better ESD protection compared to lower capacitance values.

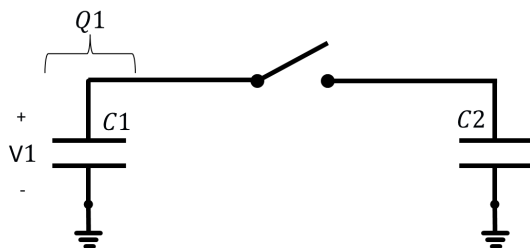

$$Q1 = C1 \cdot V1$$

Capacitor Network before Discharge (Switch Open)

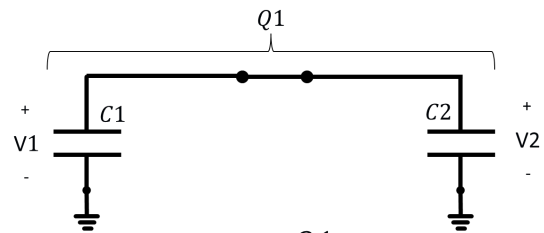

$$V2 = \frac{Q1}{C1 + C2}$$

Capacitor Network After Discharge (Switch Closed)

By substituting  $C1 \cdot V1$  for  $Q1$  in the equation on the right, we can now calculate the resulting ESD voltage based on the capacitors and ESD charge voltage.

$$V2 = \frac{C1 \cdot V1}{C1 + C2}$$

Below is a graph of the resulting ESD voltage versus ESD MLCC capacitance when applying a 25kV ESD source voltage and 150pF source capacitance. The results show a significant decrease in resulting voltage versus capacitance.

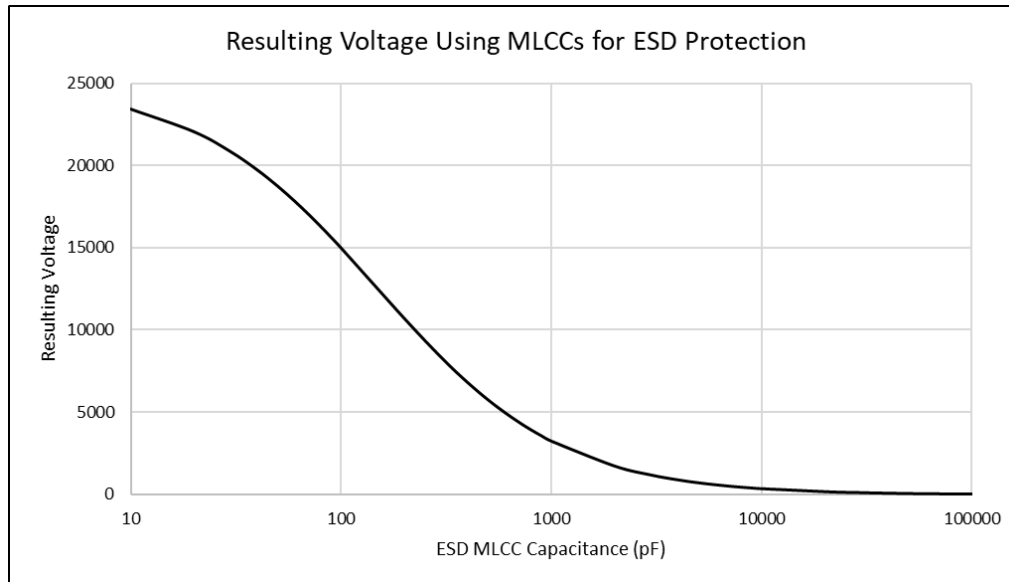

Resulting Voltage vs ESD MLCC Capacitance with a 25kV ESD Source Voltage

A key consideration in selecting MLCCs for ESD suppression is taking into account the capacitance change versus DC-Bias. For details on this phenomenon, see question [Why Does Capacitance Change with DC-Bias?](#) As voltage increases on the MLCC, the capacitance will decrease reducing the effectiveness to absorb the ESD charge. Therefore, it is recommended to us YAGEO Group's [Y-SIM tool](#) to evaluate the worst-case capacitance and impact on the resulting voltage from the above equation.

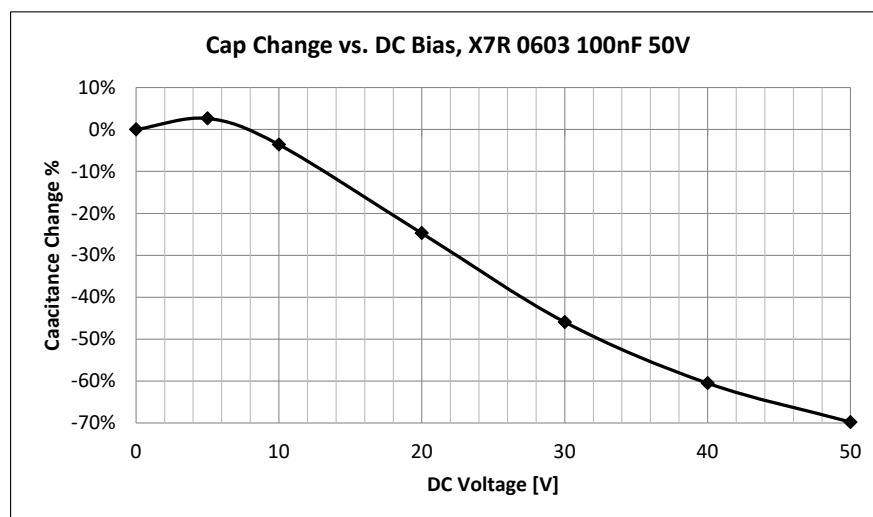

Capacitance Change vs DC-Bias for Class II X7R MLCC

## DC and AC Voltage Considerations

### What is the maximum AC voltage I can use on a DC rated MLCC?

YAGEO Group’s Surface Mount Device (SMD) Multilayer Ceramic Capacitors (MLCCs) are normally rated at DC voltages. However, in many cases, applications require AC voltages that can be high enough to cause degradation. The below guidelines can be used to convert the DC rated voltage to max allowable AC voltage.

When rating MLCCs for AC applications, the following three operating regions need to be considered: Voltage Limited Region, Thermal Limited Region, and the Current Limited Region.

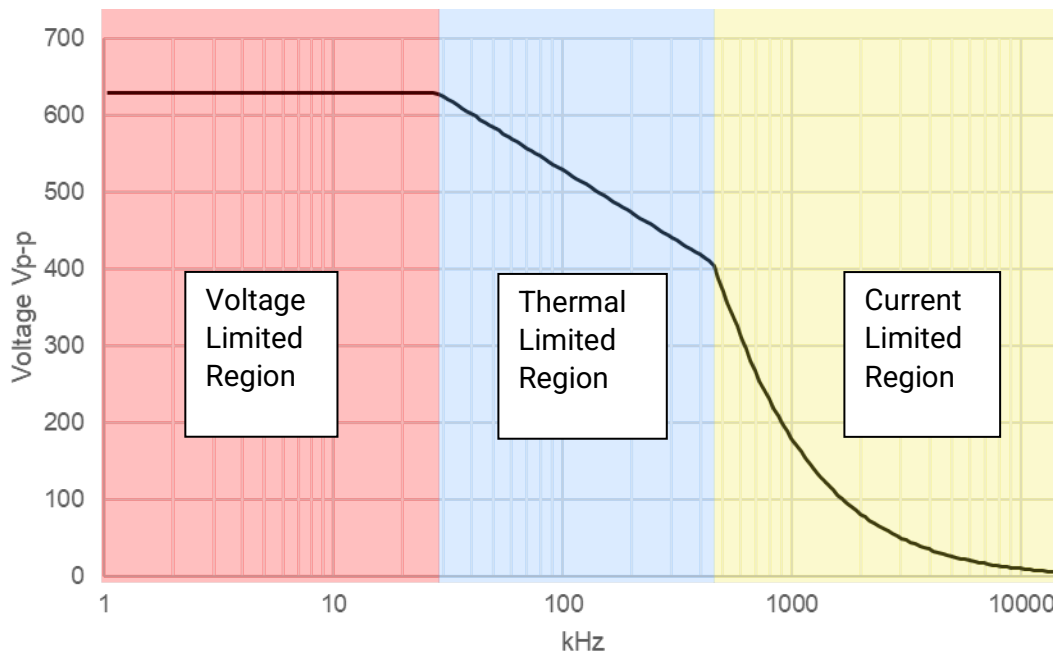

Note that these are only guidelines and do not serve as an absolute AC voltage and current rating of the MLCC in the application. Validation of the MLCC under full power operation is still required to assess product capability.

## Guidelines in the Voltage Limited Region

Definitions:

- $V_{rated\ DC}$ : DC rated voltage of MLCC
- $V_p$ : Peak voltage of AC waveform
- $V_{pp}$ : Peak to Peak voltage of AC waveform
- $V_{rms}$ : RMS voltage of AC waveform
- $V_{dc}$ : DC voltage of AC waveform (offset)

When calculating the AC rated voltage of an MLCC, both Guideline #1 and Guideline #2 below must be followed.

<b>Guideline #1 (Sinusoidal with DC)</b>	<b>Guideline #2 (Sinusoidal no DC)</b>	<b>Guideline #3 (Pulse)</b>
$V_p + V_{dc} < V_{rated\ DC}$	$V_p < \frac{V_{rated\ DC}}{2} \Rightarrow V_{rms} < \frac{V_{rated\ DC}}{2\sqrt{2}}$	$V_p < V_{rated\ DC}$
<p>Rated DC Voltage (<math>V_{rated\ DC}</math>) ——— Peak AC+DC Voltage (<math>V_p + V_{dc}</math>) - - -</p>	<p>Rated DC Voltage (<math>V_{rated\ DC}</math>) ——— Peak AC Voltage (<math>V_p</math>) - - -</p>	<p>Rated DC Voltage (<math>V_{rated\ DC}</math>) ——— Peak AC Voltage (<math>V_p</math>) - - -</p>

- When AC voltage is superimposed on DC voltage, the total voltage ( $V_p + V_{dc}$ ) must be less than the DC rated voltage of the MLCC.
- If a transient or pulsed voltage is applied, it must be below the DC rated voltage of the MLCC.

## Guidelines in the Thermal Limited Region

This region is denoted as an area where continuous temperature rise can occur under high AC voltages at high frequencies. Thusly the AC voltage is derated further from the Voltage Limited Region to reduce the possibility of continuous temperature rise. To identify the safe operating voltage in this region, please refer to the K-SIM Current and Voltage graph for the part specific recommendation.

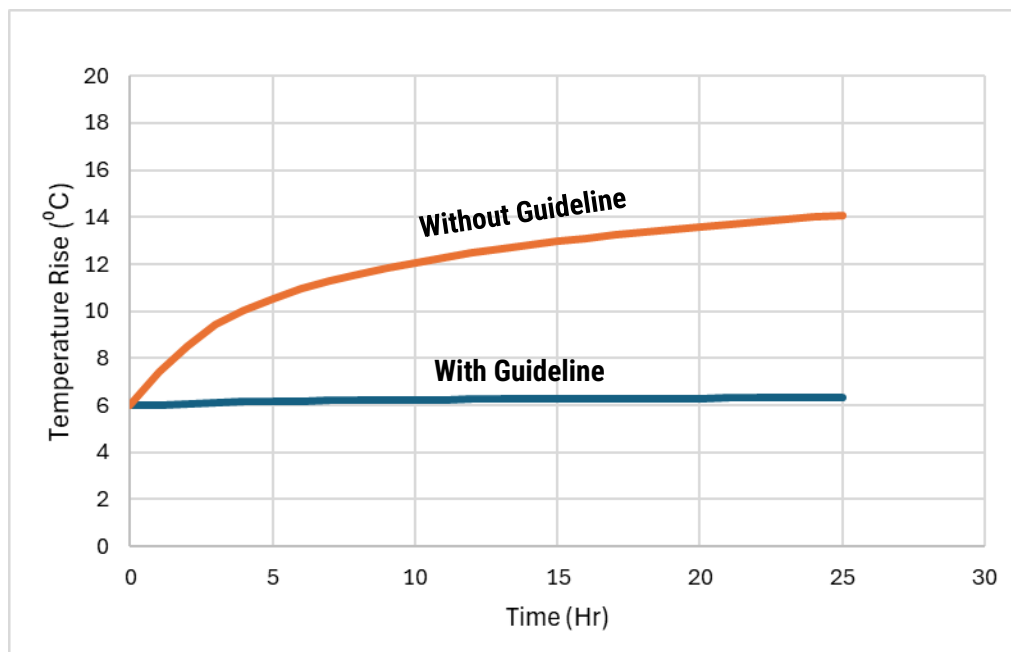

## Guidelines in the Current Limited Region

In addition to the guidelines above, YAGEO Group recommends that the max temperature of the MLCC never exceed the operating temperature during the lifetime of the application.

Definitions:

$R_{\theta}$ : Thermal Resistance of MLCC

I: RMS current through the MLCC

P: Dissipated Power

$T_{rise}$ : Self-Temperature Rise (dT)

ESL: Equivalent Series Inductance

ESR: Equivalent Series Resistance

C: Capacitance



$$P = I^2 ESR$$

$$T_{rise} = P \cdot R_{\theta}$$

Note that these are only guidelines and do not serve as an absolute AC voltage and current rating of the MLCC in the application. Validation of the MLCC under full power operation is still required to assess product capability.

## Is it safe to use ceramic capacitors above their rated voltage?

Key Words: Derating

MLCCs are designed and tested to be used up to full rated temperature and voltage per the datasheet and specification sheet. YAGEO Group does not recommend exceeding the rated voltage or temperature, even for a short duration of time.

## Do YAGEO Group ceramic capacitors require voltage derating?

It is common for some capacitor technologies such as Tantalum and Film to require voltage derating at elevated temperatures. Even when using within the capacitors maximum operating temperature, these capacitors may require a reduced voltage to maintain reliability.

However, YAGEO Group ceramic capacitors are designed and qualified to operate at full rated temperature and voltage. For example, an X7R 100nF 50V rated MLCC with an operating temperature of 125°C can be used at 50V and 125°C. No derating is required.

## Safety Certified Ceramic Capacitors

Where can I find safety certificates for YAGEO Group products? Can I obtain a CB report?

Safety certifications for YAGEO Group Safety Certified products can be found in two locations:

[YAGEOGroup.com](https://www.yageogroup.com) > [About](#) > [Sustainability](#) > [Quality](#)

Please see **Product-Level Certificates** pertaining to the series of interest.

Here you are able to view and download a PDF of our safety certification which demonstrates our compliance to IEC 60384-14.

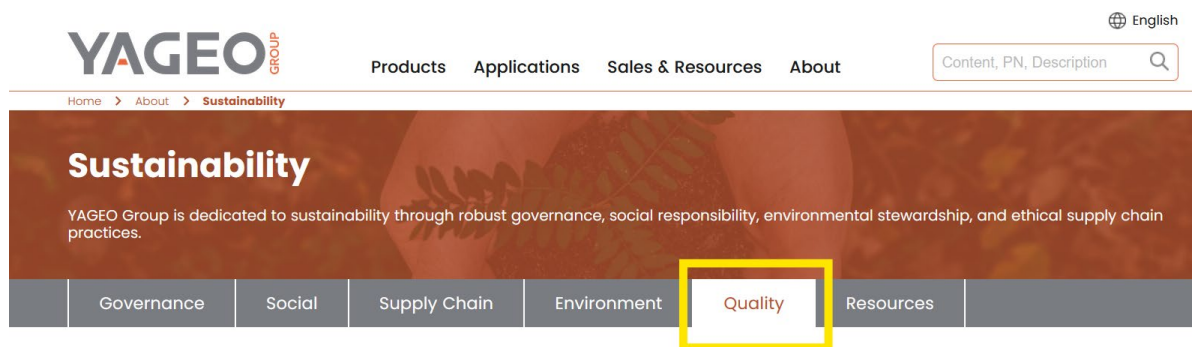

YAGEO Group has implemented ISO 9001 and other quality management systems, earning certifications from AIAG, VDA/QMC, and IATF—demonstrating its adherence to international standards. In 2023, YAGEO Group strengthened its quality policy, “Quality is the Foundation of the Future,” by integrating KPIs across all customer-facing and support processes to ensure continuous monitoring and improvement. This comprehensive approach underscores a commitment to zero defects, customer satisfaction, and long-term success.



Or in the individual product family datasheets.

[Radial Leaded Ceramic Disc Capacitors](#)

[Safety Standard Recognized, C700, Encapsulated, KJY Type, X1 440/400 VAC/Y2 300/250 VAC \(Industrial Grade\)](#)



### Approval Standard and Certification No.

Safety Standard	Standard No.	Subclass	Working Voltage	Certificate No.
TUV	IEC 60384-14	X1	400 VAC	<a href="#">R50466992</a>
		Y2	250 VAC	
TUV	IEC 60384-14	X1	440 VAC	<a href="#">R50466992</a>
		Y2	300 VAC	
UL CAN/CSA	UL 60384-14 and E60384-14	X1	400 VAC	<a href="#">E356389</a>
		Y2	250 VAC	
UL CAN/CSA	UL 60384-14 and E60384-14	X1	440 VAC	<a href="#">E356389</a>
		Y2	300 VAC	

*These devices are TUV and UL recognized for antenna coupling and AC line-to-line (Class X) and line-to-ground (Class Y) applications per IEC60384-14 and UL 60384-14.*

## Can a Y2 capacitor be used in place of a Y1?

No, you cannot use a Y2 in place of a Y1. However, you can use a Y1 in place of a Y2. Both X2 and Y2 are primarily used in residential applications and do not necessarily require the mitigation of much higher impulse voltages that industrial applications tend to see. In the table below, you can see that sub classification per IEC 60384-14 specifies the peak impulse that each subclass can handle. Intuitively, the Y2 which is tested at 5kV peak impulse is not rated to comply with Y1's rating of 8kV.

Subclass	Peak Impulse Voltage in Service	Application	Peak Impulse before endurance test
<b>X1</b>	>2.5 kV ≤ 4.0 kV	High pulse application (Industrial)	4 kV per C ≤ 1μF 4/√C kV per C >1μF
<b>X2</b>	≤ 2.5 kV	General purpose (Home appliance)	2.5 kV per C ≤1μF 2.5/√C kV per C >1μF

Subclass	Rated Voltage	Type of Bridged Insulation	Peak Impulse before endurance test
<b>Y1</b>	≤ 500 Vac	Double insulation or reinforced Insulation (Industrial)	8 kV
<b>Y2</b>	≥ 150 Vac ≤ 500 Vac	Basic insulation or supplementary insulation (Home appliance)	5 kV

Please consider this matrix when determining substitutions.

Class	Substitution <sup>1</sup>
X1	Y1 or Y2
X2	X1, Y1, or Y2
Y2	Y1
Y1	None

<sup>1</sup>Substitutions are of the same or higher voltage rating.

### Can safety certified capacitors be used in DC voltages?

IEC 60384-14 defines that all safety rated capacitors have a DC safety rating equal to the AC rating.

i.e. a 250VAC safety certified capacitor would have a 250VDC rating.

### Can safety certified capacitors be used above their rated voltage?

The operating voltage for safety capacitors must always be their rated voltage or less. Although, the operating voltage is fundamentally what the part should operate under in normal conditions, these capacitors must be designed with the intention of mitigating impulses from being passed down the circuit. Considering this, one should additionally ensure that the class is properly chosen so that the correct impulse voltage is accounted for. These capacitors are not meant to be used in conditions that imply any higher operating voltages or impulse voltages than what is specified and approved via the IEC 60384-14 specification. Failure to adhere to these directions could imply risk of fire or shock depending on the orientation/application of the capacitor, Class-X or Class-Y.

### Is the moisture sensitivity level different for Safety Certified disc products compared to SMD?

Yes, YAGEO Group denotes our safety certified disc products to have an MSL rating Level 2.

## HiQ High Frequency RF Capacitors (CBR Series)

### What does RF Stand For?

RF stands for Radio Frequency, which has a frequency range of 30kHz – 300GHz. However, when referring to RF capacitors, the frequency range is usually 300MHz – 50GHz. Below 300MHz, standard MLCCs are suitable.

## KEMET HiQ-CBR & YAGEO CQ Series

High Q Application Frequency Range

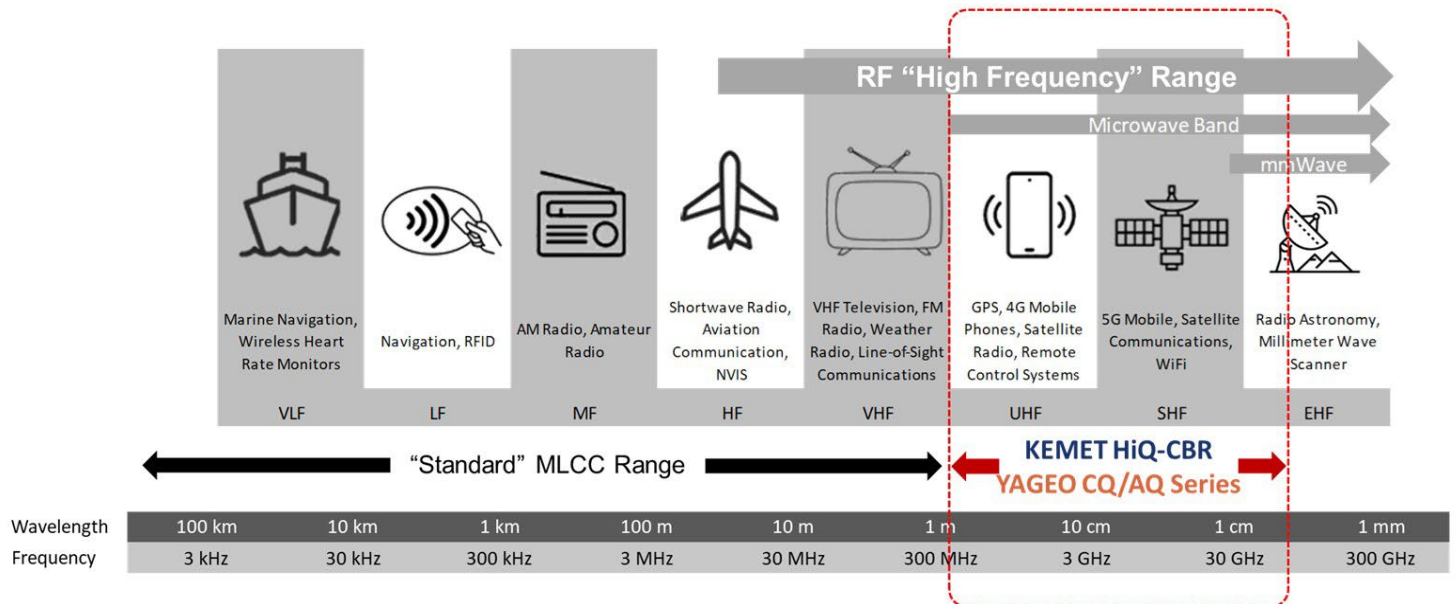

### What is an RF Capacitor?

An RF capacitor is a capacitor whose “characteristics” are optimal at RF frequencies.

Key Characteristic	RF Capacitor Requirements
ESR (Equivalent Series Resistance)	Lowest possible ESR at RF frequencies
Q (Quality Factor)	High Q at RF frequencies
SRF (Series Resonant Frequencies)	High SRF as high as possible
TCC (Temperature Coefficient of Capacitance)	Minimal capacitance shift across temperature

Therefore, for RF capacitors, materials are chosen, and designs are optimized so that the capacitor’s characteristics are optimal at the higher frequencies.

### What are typical applications for RF capacitors?

RF MLCCs are used for bypass, coupling, filtering, impedance matching and DC blocking purposes.

Typical applications include:

- RF power amplifiers (PA)
- Cellular base stations (4G, 5G)
- Wireless LAN
- Telecommunication Networks
- GPS
- Bluetooth
- Radar
- Automotive V2X, Safety Systems, Power Train, Communication Systems

## What is the difference between standard Ceramic Capacitors and HiQ RF capacitors?

Roughly 99% of all ceramic capacitors shipped every year are Base Metal Electrode systems where the inner electrodes are made of nickel. Since RF capacitors require very low loss at high frequencies, the internal electrodes are either Palladium Silver for Precious Metal Electrode (PME) systems or Copper for Base Metal Electrode (BME) systems.

Since nickel is a ferrous material, its resistance increases dramatically at higher frequencies compared to copper. The bottom left plot below shows resistance of a 1.5mm diameter wire made from copper and nickel versus frequency. The plot shows that the nickel wire's resistance starts increasing above 10MHz while the copper wire's resistance increase is negligible in the GHz frequency range. Therefore, nickel electrodes are not preferred for RF capacitors.

In some RF capacitors, PdAg may be used which does provide good ESR at higher frequencies. However, with the increasing costs of precious metals, copper-based RF capacitors provide a great balance of excellent RF performance at a competitive cost.

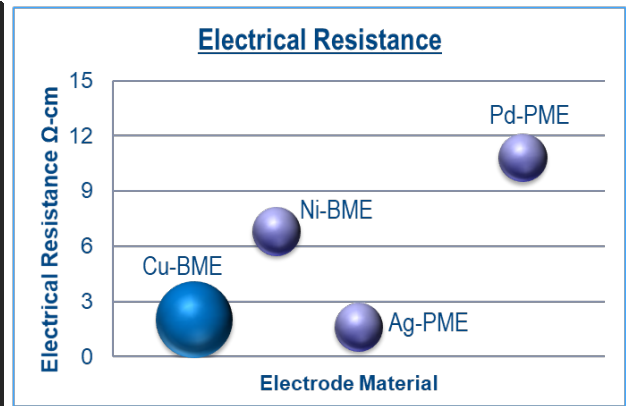
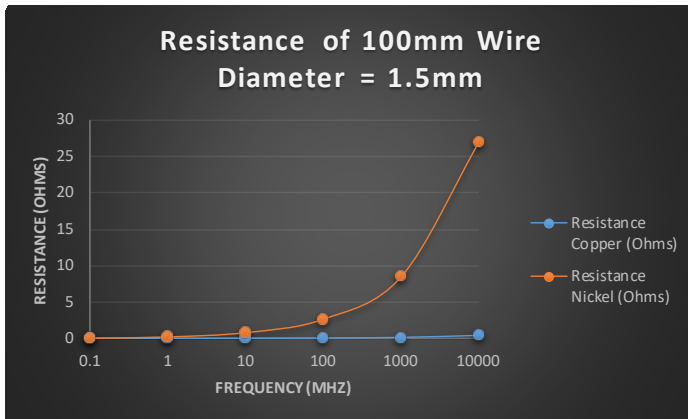

KEMET's CBR & YAGEO's CQ series utilizes copper electrodes to maintain very low losses at high frequencies.

Characteristic	Standard Ceramic Capacitor	HiQ RF Ceramic Capacitor
Frequency Range	Low Frequencies <100MHz	Higher frequencies >100MHz
Electrode System	Nickel (BME)	Copper (BME) PdAg (PME)
ESR	Low ESR	Very Low ESR
Q-Factor	Moderate Q-Factor	High Q-Factor
Class I or Class II	Class I or Class II Dielectrics	Class I

## What makes KEMET's CBR Automotive Grade RF capacitors automotive grade?

KEMET's CBR Automotive Grade RF capacitors and YAGEO's AQ Automotive Grade RF Capacitors both utilize the same dielectric and electrode materials as the standard CBR & CQ series. However, the automotive grade CBR & AQ series is qualified, manufactured and tested per the stringent AEC-Q200 automotive standard.

## What is Q or Quality Factor and how does it relate to Dissipation Factor?

Q or quality factor represents the efficiency of a capacitor and is the ratio of energy stored in a capacitor to the energy dissipated as thermal losses due to the equivalent series resistance (ESR) and  $I^2R$  losses. At higher frequencies, higher ESR can cause excessive heating in the capacitor beyond its max allowable power dissipation. Since Q is inversely proportional to ESR, lower ESR at high frequencies will have higher Q at high frequencies. Therefore, higher Q capacitors are preferred by RF designers for high frequency applications.

Q is also related to Dissipation Factor as seen in the equation below. For lower frequency applications, DF is traditionally used instead of Q.

$$Q = \frac{X}{ESR} \quad Q = \frac{1}{DF}$$

## What are S-Parameters and how do I obtain them?

S-Parameters, or scattering parameters are used to describe how RF energy travels through a network (filter, amplifier, capacitor, etc). As an analogy, S-Parameters can be thought of like light traveling through a pair of glasses. Some of the light reflects off the lens towards the source, some light travels through the lens to the eye, and some of the light will be absorbed by the lens. Similarly, RF energy can be thought of as a traveling wave. Some of those waves will bounce back towards the source, some waves will travel through the network, and others will be absorbed. S-Parameters are a convenient way of quantifying those characteristics of the network.

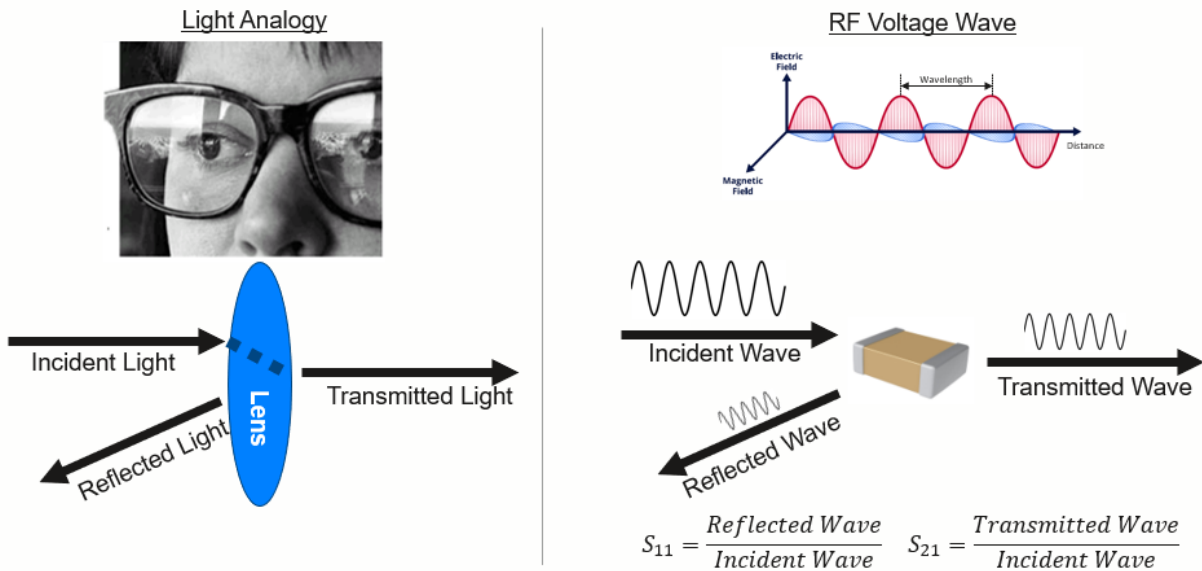

S-Parameters are important in RF design because they are relatively easy to measure and work well at high frequencies versus other parameters that are derived from direct voltage and current measurements. They can be used to not only characterize capacitors, but also inductors, transistors, PCB traces, amplifiers, and even complex systems.

### How to obtain S-Parameters for KEMET's CBR series?

S-Parameters are provided as a text-based ASCII file and downloaded from the KEMET website.

```
!Agilent Technologies,E5071C,MY46109480,A.09.54
!Date: Tue Oct 11 20:23:29 2011
!Data & Calibration Information:
!Freq S11:SOLT2(ON) S21:SOLT2(ON) S12:SOLT2(ON) S22:SOLT2(ON)
# Hz S dB R 50
50000000 -3.760025e-001 -1.745230e+001 -1.070520e+001 7.279950e+001 -1.070309e+001 7.281087e+001 -3.737441e
74937500 -8.168459e-001 -2.525207e+001 -7.644260e+000 6.481506e+001 -7.641570e+000 6.482366e+001 -8.142310e
99875000 -1.360752e+000 -3.223251e+001 -5.704231e+000 5.780029e+001 -5.702769e+000 5.781035e+001 -1.357891e
124812500 -1.973216e+000 -3.834190e+001 -4.391318e+000 5.161158e+001 -4.389353e+000 5.162188e+001 -1.970618e
149750000 -2.616565e+000 -4.365442e+001 -3.463572e+000 4.626452e+001 -3.460819e+000 4.627317e+001 -2.613514e
174687500 -3.260025e+000 -4.833230e+001 -3.737441e+000 4.162310e+001 -3.737441e+000 4.162310e+001 -3.260025e
```

## Do I need to be concerned with PCB and pad dimensions when using RF capacitors?

When MLCCs are mounted to PCBs, the discrete component now becomes a part of an electrical system consisting of other components and materials. The capacitor does not operate independently from the other components and materials, but the overall properties may be influenced by them. When we mount any ceramic capacitor to a PCB, there will be parasitic effects due to the PCB and pad dimensions that need to be considered in the electrical performance. For example, the pad dimensions and ceramic electrodes will have some parasitic capacitance to the ground plane of the PCB and the pad dimensions will have some parasitic capacitance between them. The inductance (or ESL) is also a function of the PCB properties. For example, thinner PCB substrates will cause the inductance to be lower since the ground plane of the PCB acts like a shield of a conductor.

### Why is this important?

Since the parasitic capacitances and inductance of MLCCs are relatively low, at low frequencies, it is not much of a concern. Even though the PCB and pad dimensions have some influence of the electrical characteristics, at lower frequencies, they are usually negligible. However, at higher frequencies, these parasitics start influencing the capacitor properties and become a major consideration in the overall design. Here, we can see an example of S11 for a 5.6pF 0805 RF capacitor up to 10GHz mounted on three different PCBs. Notice after about 800MHz, S11 for all three PCBs starts deviating from one another considerably.

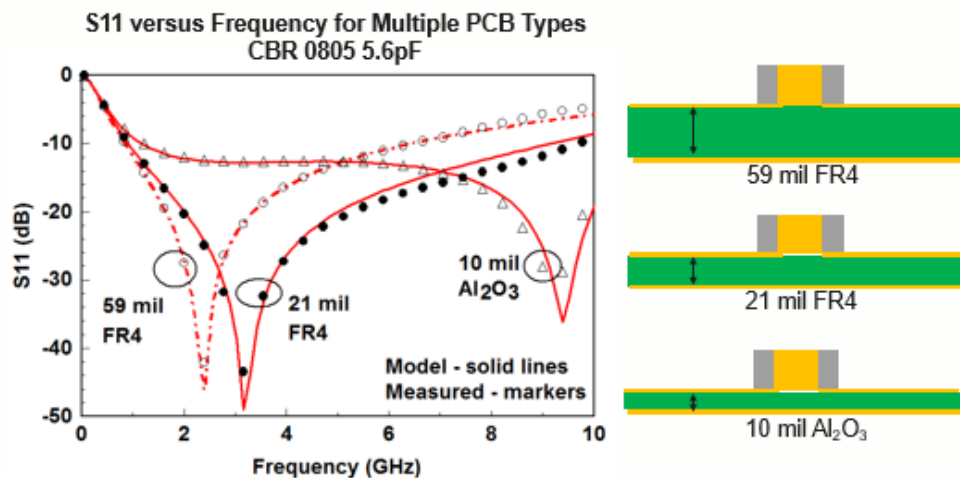

This shows just how important taking into consideration PCB conditions can be.

This is one limitation with S-Parameter data. S-Parameters are data taken on a single capacitor measured under a single PCB and pad dimensions. Therefore the actual performance of the RF capacitor can be different from the customer's actual use conditions, so designers need to consider the effects of PCB and pad dimensions.

## What are Modelithics Models and how do I obtain them?

In order to help customers design in KEMET’s CBR RF capacitor series, KEMET has partnered with Modelithics to provide customers with substrate scalable models that can be downloaded and simulated in popular EDA design tools. These measurement-based models allow designers to input capacitance value, tolerance, pad dimensions, and PCB information. The result is a full substrate scalable model that accurately predicts the behavior of the actual PCB performance to achieve first-pass-design-success.

To inquire about obtaining KEMET’s Modelithics Models for the CBR series, please visit. ([LINK](#))



### Simulating Real World Parasitics

- Capacitance and Tolerance
- PCB Properties
- Pad Dimensions

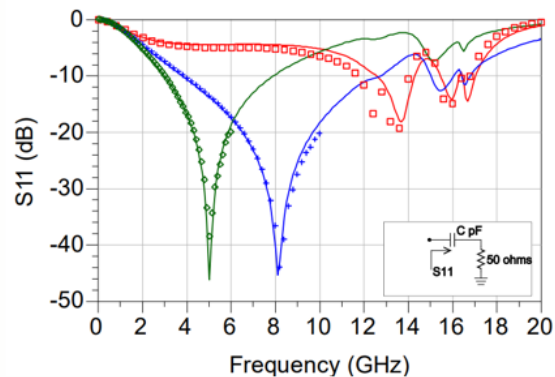
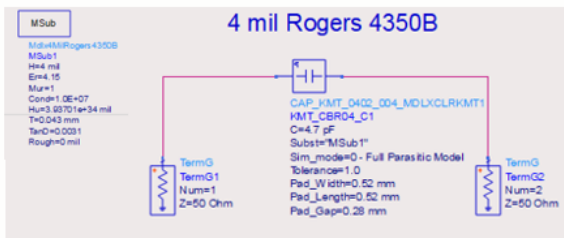

Lines – Model, Symbols – Measured Data

- 4 mil Rogers 4350B
- + 20 mil Rogers 4003C
- ◇ 60 mil Rogers 4003C

## KONNEKT Technology

### What is KONNEKT™ Technology?

KONNEKT™ is a patented high-density packaging technology that allows MLCCs to be bonded together without the use of metal frames. KONNEKT technology utilizes innovative transient liquid phase sintering (TLPS) material which has low temperature reaction of low melting point metal or alloy with a high melting point metal or alloy to form a reacted metal matrix. The result is a highly conductive bonding material that can be used to connect multiple MLCCs together to form a single surface mountable component.

<https://yageogroup.com/SalesResources/ResourceLibrary/news/14069>

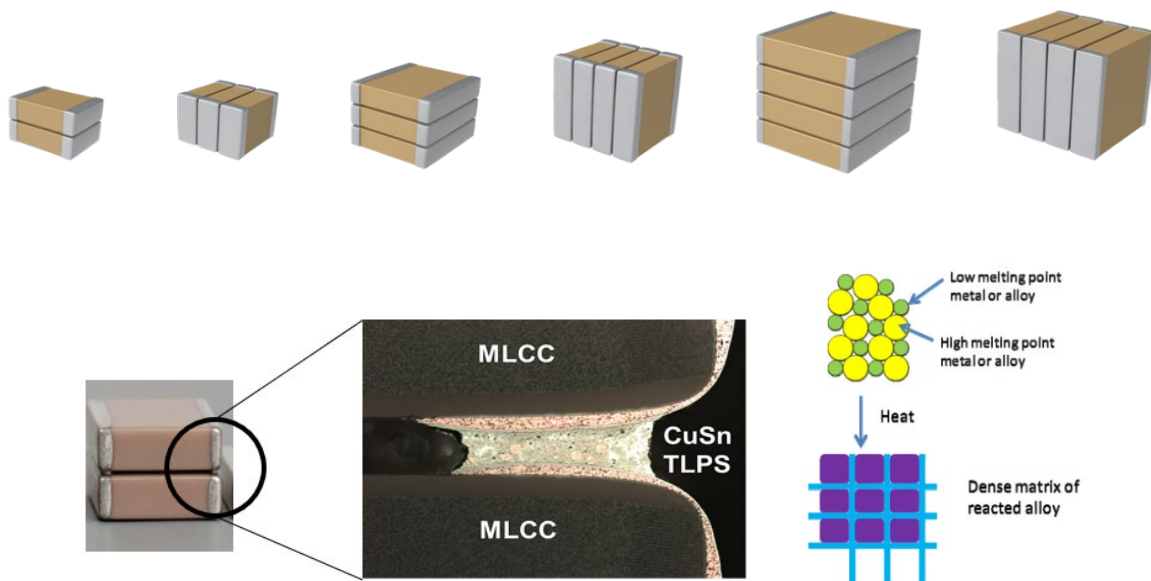

### Is KONNEKT™ Technology Pb-Free and RoHS Compliant?

Yes, KONNEKT Technology is 100% Pb-Free, RoHS and Reach Compliant with no exceptions.



### Why does KONNEKT™ use TLPS and not metal frames?

Metal frames add ESR, ESL, and thermal resistance to capacitors reducing their power handling capability. Since MLCCs are often used in high power applications such as wireless chargers and resonant converters, reducing these losses is critical to minimize self-heating. KONNEKT technology allows for the lowest ESR, ESL and thermal resistance possible in the form factor.

## What is the difference between Standard and Low-Loss orientation?

The terms “Standard” and “Low-Loss” refer to the orientation of the KONNEKT stack when mounted to a PCB. In standard orientation, the MLCCs are parallel to the PCB plane. In Low-Loss orientation, the MLCCs are perpendicular to the PCB plane.

Low-Loss orientation enables higher power handling capability by lowering the ESR (Effective Series Resistance), ESL (Effective Series Inductance), and Thermal Resistance (Rth). This makes the Low-Loss orientation of KONNEKT the ideal choice for high power density applications such as wireless chargers and resonant converters.

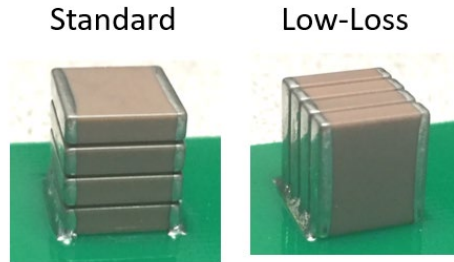

EIA 3640 KONNEKT in Standard and Low-Loss Orientation

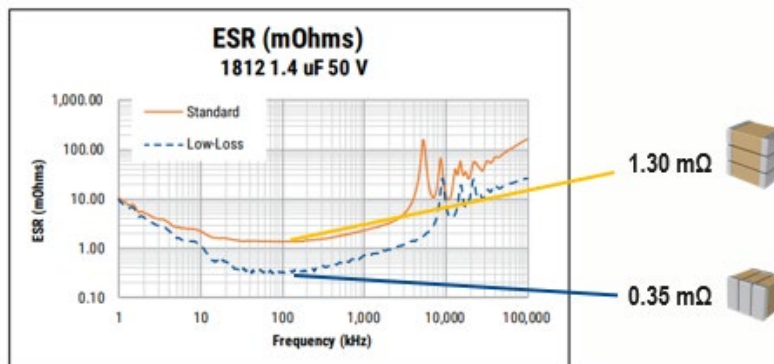

Typical ESR for U2J with KONNEKT 1812 1.4uF 50V

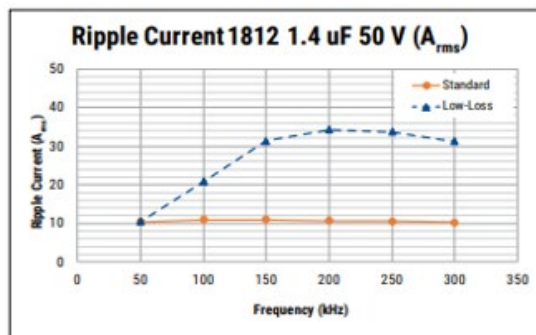

Typical Ripple Current and ESR for U2J with KONNEKT 1812 1.4uF 50V

ESL	
Standard	1.6 nH
Low-Loss	0.4 nH

## Why are some KONNEKT capacitors available in standard orientation but not Low Loss?

KEMET offers KONNEKT technology in Low-Loss orientation to reduce ESR, ESL, and thermal resistance. However, in some cases, Low-Loss orientation is not practical given the aspect ratio of the MLCCs and therefore is not offered. For example, CKC33C444KCGLCAUTO (KC-LINK with KONNEKT, 2-Chip, EIA 3640, 440nF, 500V, K Tolerance) is only available in standard orientation as seen below.

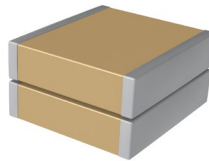

KC-LINK with KONNEKT, 2-Chip, EIA 3640 in Standard Orientation

See KEMET KONNEKT datasheets for details on product offering.

<https://www.YAGEOGroup.com/en/us/capacitors/ceramic/konnekt.html>

## Is there a difference between the materials or construction of standard orientation KONNEKT capacitors versus Low-Loss orientation?

No, the material and construction between standard orientation and low loss orientation is identical. The terms "Standard" and "Low-Loss" refer to the orientation of the KONNEKT stack when mounted to a PCB. In standard orientation, the MLCCs are parallel to the PCB plane. In Low-Loss orientation, the MLCCs are perpendicular to the PCB plane. Before shipping the capacitors from the KEMET manufacturing facility, the KONNEKT capacitors are placed in either standard or low loss orientation in the Tape and Reel pocket. This allows the capacitors to be Pick-N-Placed in the correct orientation.

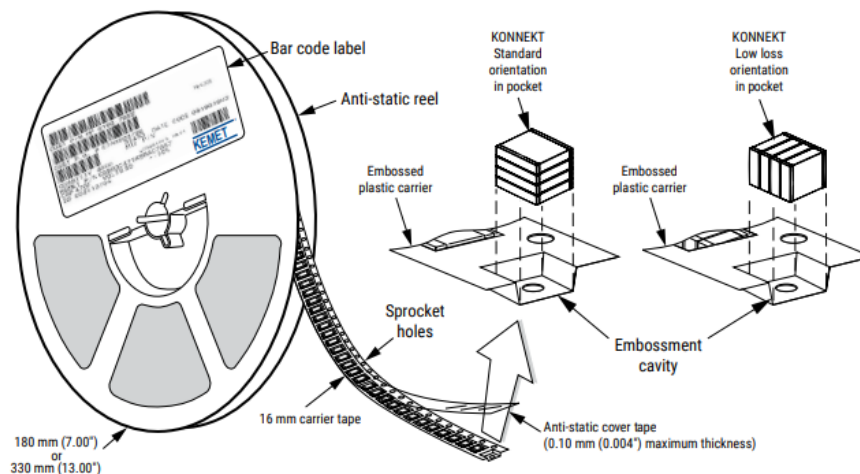

## What are the recommended soldering techniques for KONNEKT capacitors?

See link below for KONNEKT Mounting Recommendations document for pad geometry, solder reflow, wave soldering, and hand soldering guidelines.

<https://yageogroup.com/content/Resource%20Library/Technical%20Article/KONNEKT-Solder-Recommendations.pdf>

## How are KONNEKT capacitors tested for vibration?

KEMET's KONNEKT capacitors are tested using the following test conditions:

### **MIL-STD-202 Method 204**

5 g for 20 minutes, 12 cycles each of 3 orientations. Note: Use 8" x 5" PCB 0.031" thick 7 secure points on one long side and 2 secure points at corners of opposite sides. Parts mounted within 2" from any secure point. Test from 10 – 2,000 Hz.

## **Reliability and Qualification**

### Where do I find YAGEO Group's Quality Documents and Certificates?

YAGEO Group Quality Documents and Certificates can be found on YAGEO Group's website in the URL below.

<https://yageogroup.com/About/Sustainability/Quality>

These Certificates includes:

- KEMET Quality Manual
- AS9100
- ISO 9001
- IATF 16949
- ISO 14001
- ISO 14064
- ISO 17025
- ISO 45001
- ISO 50001
- Safety Certificates

### Where can I find Qualification Reports for Ceramic Capacitors?

YAGEO Group provides qualification and reliability reports for most grades of MLCCs. To request a qualification report, contact your local sales representative.

## Simulation (Y-SIM) and Testing

### Does YAGEO Group offer a tool to simulate electrical performance of MLCCs?

YAGEO Group's Y-SIM is a popular design tool that simulate a capacitor's impedance, ESR, capacitance, inductance, current and voltage, all over frequency as well as capacitance versus DC bias and temperature rise versus ripple current. Each of these plots can be simulated over the user's application parameters such as DC bias and ambient temperature and with parallel combinations. The tool allows for the export of simulated data in the forms of CSV files, spice models, S2P files and picture images.

Each of these characteristics are derived from real measurements on production batches to provide the most accurate response.

<https://ksim3.kemet.com/capacitor-simulation>

### Are S-Parameters available for YAGEO Group MLCCs?

Yes. YAGEO Group's Y-SIM tool can be used to simulate S11 and S21 versus frequency as well as provided a downloadable S2P file.

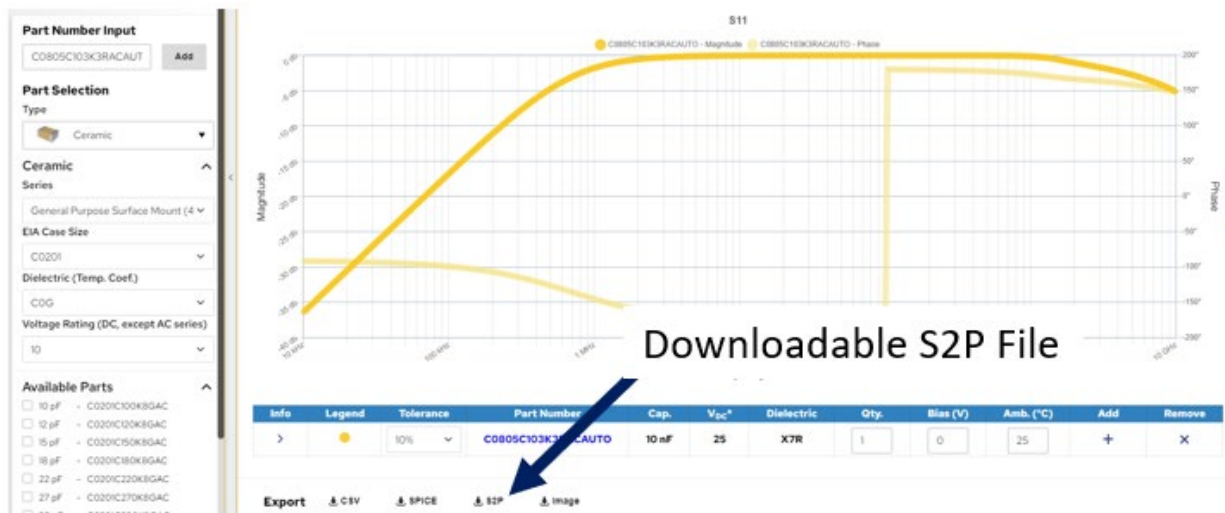

## After simulating a part in Y-SIM, how do I get samples?

After selecting a part number and simulating any characteristic, click on the YAGEO Group part number below the graph and then REQUEST SAMPLES.

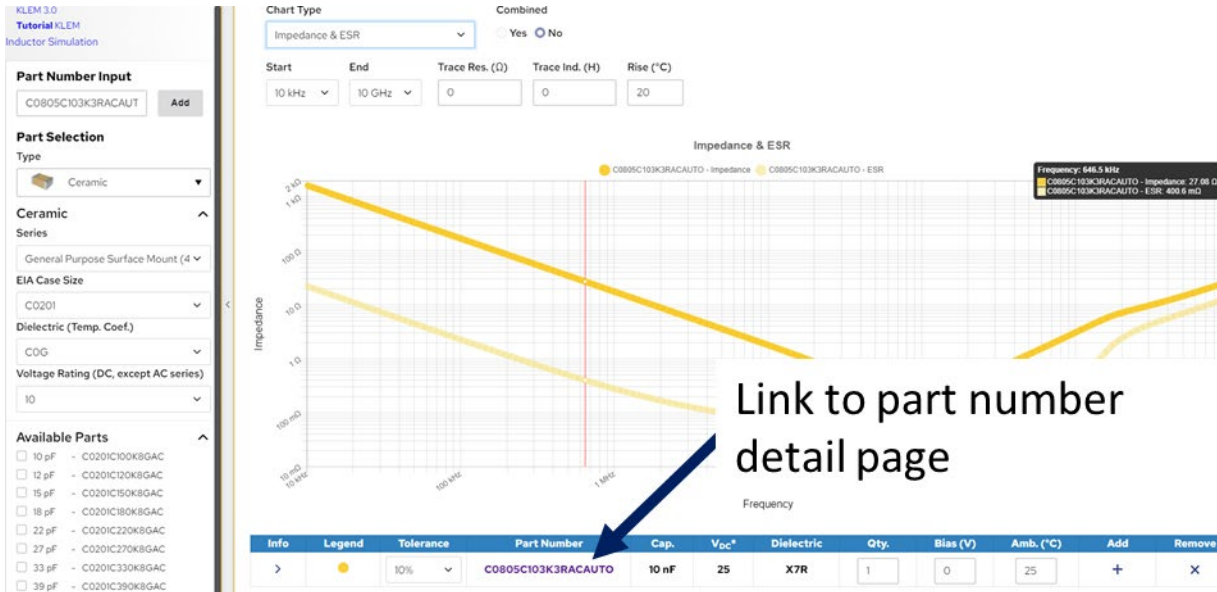

Link to part number detail page

Home > Capacitors > Ceramic > C0805C103K3RACAUTO  
[Back To Results](#)

### C0805C103K3RACAUTO

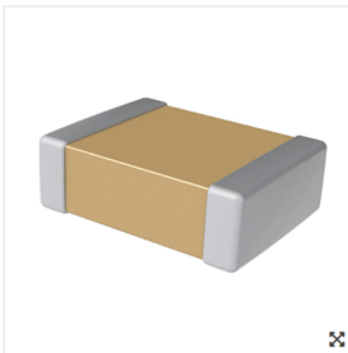

SMD Auto X7R, Ceramic, 0.01 uF, 10%, 25 VDC, X7R, SMD, MLCC, Temperature Stable, Automotive Grade, 0805

#### KEY RESOURCES

- [Datasheet](#)
- [Specsheet](#)
- [K-SIM](#)
- [RoHS Compliance Certificate](#)
- [STEP/CAD](#)
- [EDA/MCAD](#)

✓ 27K+ IN STOCK  
[REQUEST SAMPLE →](#)

Click on REQUEST SAMPLE

## What do I do if a part number is not available in Y-SIM?

If searching for a YAGEO Group part number in Y-SIM returns the error, “No match found”, please verify you are using a valid part number. This can be done by using YAGEO Group’s website and entering the part number in the search bar. <https://yageogroup.com/>

If the part number is valid, this means the part type has not been loaded into the Y-SIM tool. To get this part added to Y-SIM, please contact YAGEO Group at <https://yageogroup.com/SalesResources/ContactUs>

## **Material Compliance**

### Do YAGEO Group Ceramic Capacitors Contain PFAS?

YAGEO Group Electronics certifies that Perfluoroalkyl and Polyfluoroalkyl Substances (PFAS) are not present in Ceramic capacitors.

### Where do I find information on Material Compliance?

YAGEO Group provides information on material compliance on the YAGEO Group website: <https://yageogroup.com/About/Sustainability/Resources>

Information available includes:

- Material Compliance document
- Environmental Compliance Certificates
- Material Declarations
- REACH & SVHC Certificate of Conformance
- Halogen Free Certificate of Conformance
- IATF Certifications
- ISO Certifications
- Sn Whisker reports
- SGS reports